

Check valves type UZZB 32 are used to close hydraulic fluid flow in one direction and allow free flow in the opposite direction.

The valves are for subplate mounting and can be installed in systems in any positions together with a connection plate.

Sealing of interfaces is provided by O-rings which are included.

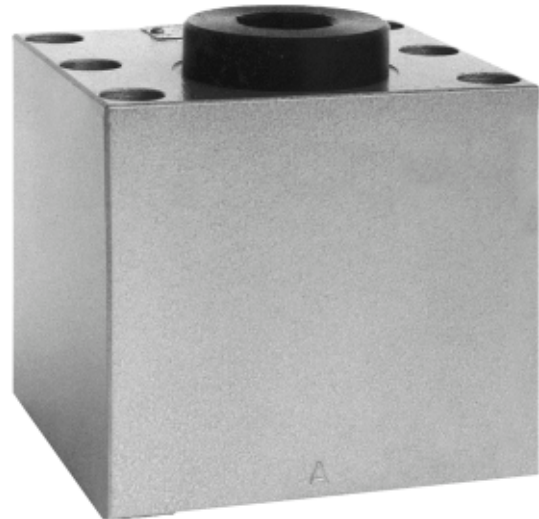

DESCRIPTION OF OPERATION

In the check valve type UZZB 32 the closing element is a poppet 2 pushed on to the seat in the housing 1. Flowing through the valve in the direction A to B fluid lifts the poppet from its seat and permits free flow. Cracking pressure depends on initial spring tension.

In the opposite direction B to A the spring and the fluid push the poppet on to the seat and close the connection without leakage.

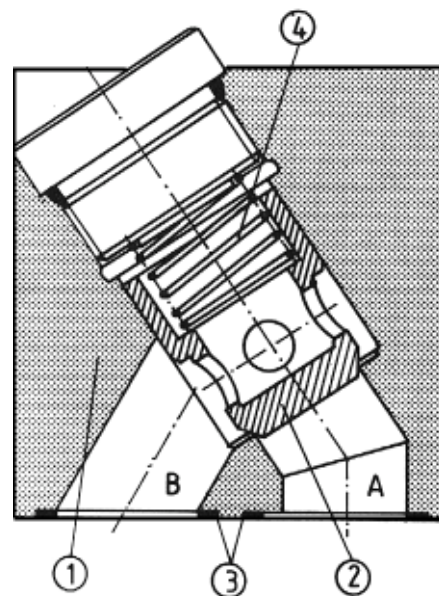

Item 3 - O-ring 42 × 3

TECHNICAL DATA

Hydraulic fluid	Mineral oil or phosphate ester
Nominal fluid viscosity	37 mm ² /s at the temperature of 328 K
Viscosity range	2.8 to 380 mm ² /s
Optimum working temperature (fluid in a tank)	313 - 328 K
Fluid temperature range	243 - 343 K
Required fluid filtration	16 μm
Recommended fluid filtration	10 μm
Maximum working pressure	31.5 MPa
Cracking pressure	0.05; 0.1; 0.15 ; 0.3 MPa
Weight	6.2 kg

OVERALL DIMENSIONS

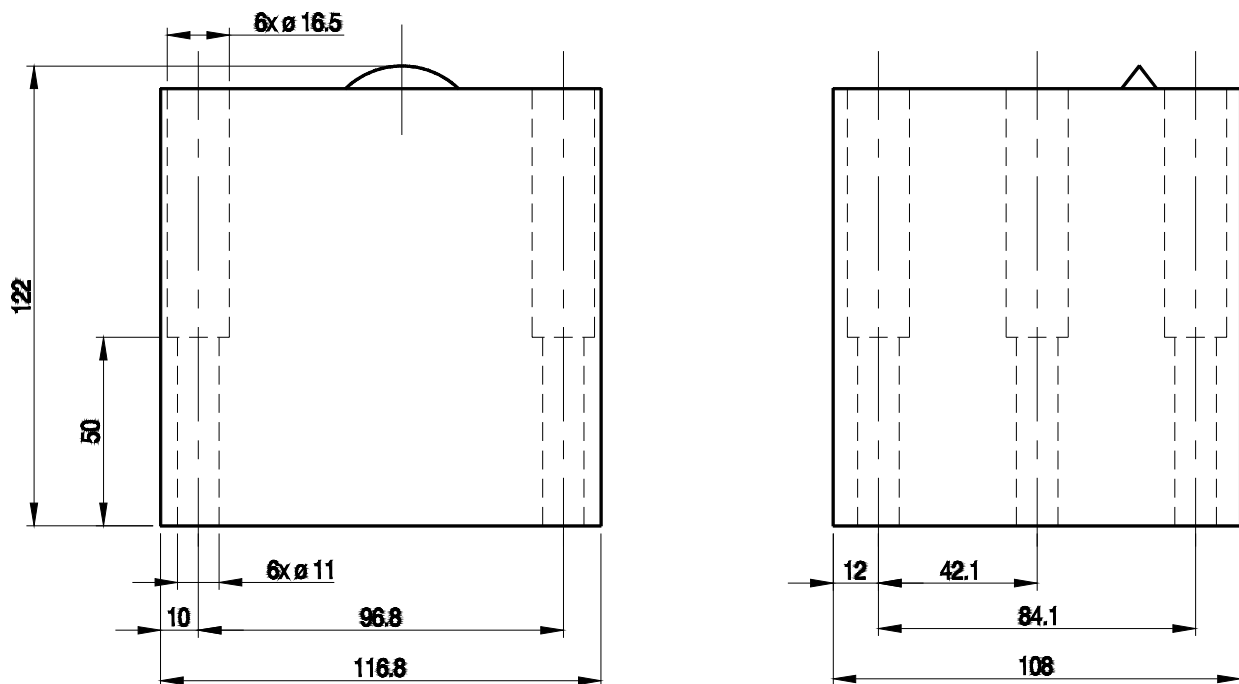

Admissible surface roughness and flatness deviation for a subplate face.

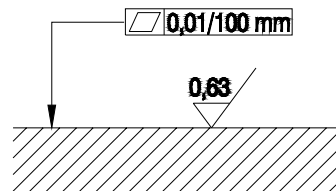

PERFORMANCE CURVES, measured at $v = 41 \text{ mm}^2/\text{s}$ and $T = 323 \text{ K}$

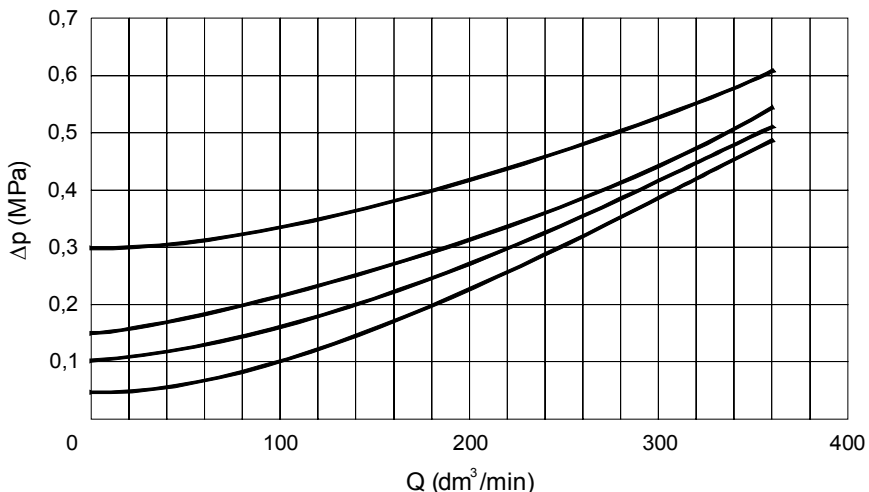

HOW TO ORDER

Orders coded in the way showed below should be forwarded to the manufacturer.



Series number :
 20 = 20
 (20-29) - installation and connection dimensions unchanged

Additional requirements in clear text
 (to be agreed with the manufacturer)

Cracking pressure
 Without spring = 00
 Cracking pressure 0.05 MPa = 05
 Cracking pressure 0.10 MPa = 10
 Cracking pressure 0.15 MPa = 15
 Cracking pressure 0.30 MPa = 30

Sealing
 Fluids on mineral oil base = no designation
 Fluids on phosphate ester base = V

Coding example : UZZB 32 - 20/10

SCHEME



Graphical symbol

CONNECTION DIMENSIONS FOR A SUBPLATE

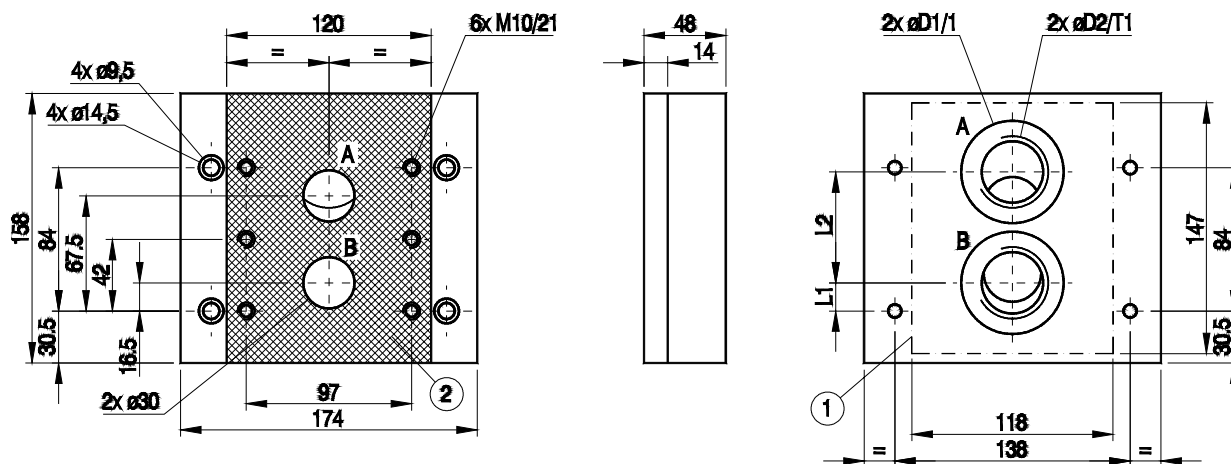

1 - Recess in subplate face
2 - Connection face

Type	L1	L2	D1	D2	T1
G27/ 01/ s	16,5	68	56	G 1 1/4	20
G28/ 01/ s	10	75	61	G 1 1/2	22
G27/ 02/ s	16,5	68	60	M42 x 2	24
G28/ 02/ s	10	75	71	M48 x 2	26

Fitting the valve to the subplate by means of the bolts M10 × 65 - 10.9 PN-74/M-82302 (DIN 912)
with torque $M_d = 69 \text{ Nm}$
The fixing bolts and subplate must be ordered separately.

PONAR WADOWICE S.A.
ul. Wojska Polskiego 29
34-100 Wadowice
tel. 033/ 823 39 43, 823 30 41
fax 033/ 873 48 80
e-mail: ponar@ponar-wadowice.pl

PONAR[®]
wadowice