

RETURN LINE FILTER, with suction connection

Series TRS 625 DN 50 PN 10

Sheet No.
1066 C

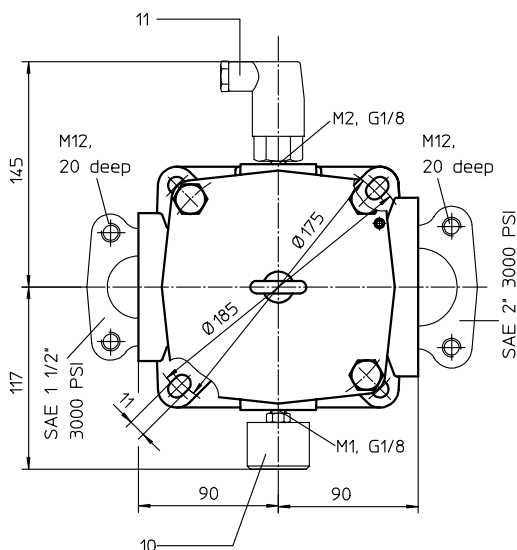
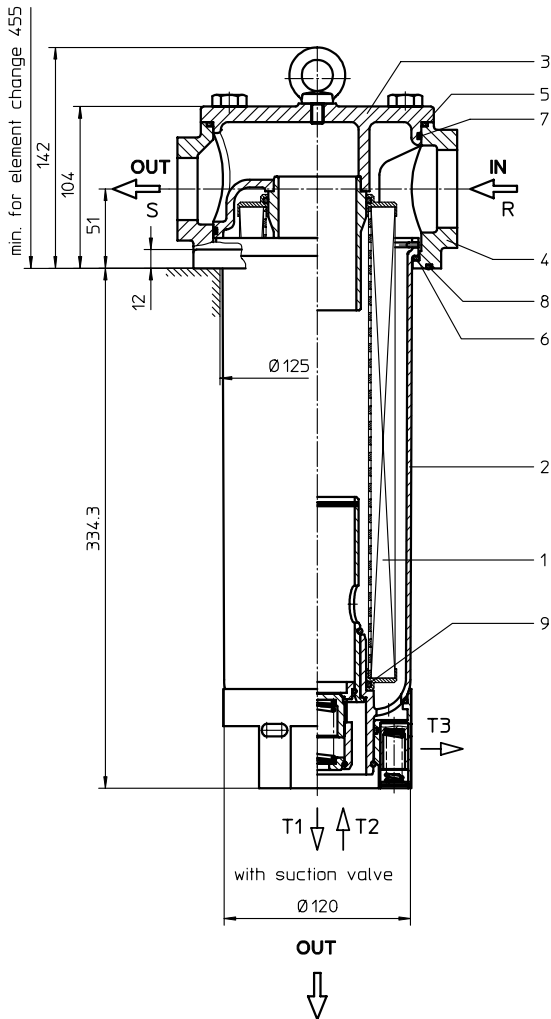

1. Type index:

1.1. Complete filter: (ordering example)

TRS.625.10VG.10.B.P. - FS. 8. - S2,5. Z. O. E2

1	2	3	4	5	6	7	8	9	10	11	12	13	14
---	---	---	---	---	---	---	---	---	----	----	----	----	----

- 1 **series:**
TRS = tank-mounted return-line filter with suction connection
- 2 **nominal size:** 625
- 3 **filter-material and filter-fineness:**
80 G = 80 μm , 40 G = 40 μm , 25 G = 25 μm
stainless steel wire mesh
25 VG = 20 $\mu\text{m}_{(c)}$, 16 VG = 15 $\mu\text{m}_{(c)}$, 10 VG = 10 $\mu\text{m}_{(c)}$,
6 VG = 7 $\mu\text{m}_{(c)}$, 3 VG = 5 $\mu\text{m}_{(c)}$ Interpor fleece (glass fibre)
25 P = 25 μm , 10 P = 10 μm paper
- 4 **resistance of pressure difference for filter element:**
10 = Δp 10 bar
- 5 **filter element design:**
B = both sides open
- 6 **sealing material:**
P = Nitrile (NBR)
V = Viton (FPM)
- 7 **filter element specification:**
- = standard
VA = stainless steel
- 8 **connection:**
FS = SAE-flange connection 3000 PSI
- 9 **connection size:**
8 = 2"
- 10 **filter housing specification:**
- = standard
- 11 **internal valve:**
S2,5 = with by-pass valve Δp 2,5 bar
- 12 **suction valve:**
Z = with suction valve
- 13 **clogging indicator at M1:**
- = without
O = visual, see sheet-no. 1616
E1 = pressure switch, see sheet-no. 1616
E2 = pressure switch, see sheet-no. 1616
E5 = pressure switch, see sheet-no. 1616
- 14 **preload pressure indicator at M2:**
- = without
E2 = pressure switch, see sheet-no. 1616

1.2. Filter element: (ordering example)

01E. 625. 10VG.10. B. P. -

1	2	3	4	5	6	7
---	---	---	---	---	---	---

- 1 **series:**
01E. = filter element according to INTERNORMEN factory specification
- 2 **nominal size:** 625
- 3 - 7 | see type index-complete filter

weight: approx. 6,0 kg

Changes of measures and design are subject to alteration!

EDV 08/03

internormen
technology

Friedensstrasse 41, 68804 Altlussheim, Germany

phone +49 - (0)6205 - 2094-0
fax +49 - (0)6205 - 2094-40

e-mail sales@internormen.com
url www.internormen.com



2. Spare parts:

item	qty.	designation	Abmessung	article-no.	
1	1	filter element	01.E 625		
2	1	filter bowl with suction valve and by-pass valve	TRS 625		
3	1	filter cover	TRS 625		
4	1	filter head	TRS 625		
5	1	O-ring	135 x 3,5	318386 (NBR)	318387 (FPM)
6	1	O-ring	120 x 4	305300 (NBR)	307991 (FPM)
7	1	O-ring	128 x 3	304602 (NBR)	308140 (FPM)
8	1	O-ring	140 x 3	304604 (NBR)	307514 (FPM)
9	2	O-ring	63 x 3,5	311189 (NBR)	311592 (FPM)
10	1	clogging indicator at M1	O, E1, E5 or E2	see sheet-no. 1616	
11	1	clogging indicator at M2	E2	see sheet-no. 1616	

3. Description:

The filters of the series TRS are tank-top mounted in-line filters. In addition to the return-line connection they have a suction connection on the clean-side. This suction connection has a preload pressure (fitting pressure) of $\geq 0,5$ bar.

This combination, return-line and suction filter, is foreseen for hydraulic circuits which are equipped with minimum 2 feed pumps (2 hydraulic circuits). The preload suction connection is for the full volume flow filtration for the pump with the smaller volume flow.

The operating status in general wherein the preload pressure and the full stream filtration are effecting the Q_R (return-line flow) $> Q_S$ (suction flow). When the operating status is $Q_R = Q_S$ no preload pressure is effective. For circuits wherein the operating status $Q_R < Q_S$ appears for a short time, the suction valve operates and as a result a feeding out of the vessel is possible without preload pressure and without filter effect.

Return-line filters in the TRS series are suitable for a working pressure up to 10 bar. Pressure peaks will be absorbed by a sufficient margin of safety.

The filter element consists of a star-shaped, pleated filter material which is supported on the inside by a perforated core tube and is bonded to the end caps with a high-quality adhesive. The flow is from outside to inside. Filter finer than $40 \mu\text{m}$ should use throw-away elements made of paper or Interpor fleece (glass fibre). Filter elements as fine as $5 \mu\text{m}_{(0)}$ are available; finer filter elements on request.

INTERNORMEN-Filters can be used for petroleum-based fluids, HW emulsions, water glycols, most synthetic fluids and lubrication fluids. Consult factory for specific fluid applications.

INTERNORMEN-Filters elements are known as stable elements which have excellent filtration capabilities and a high dirt retaining capacity, therefore having a long service life. Due to its practical design, the return-line filter is easy to service.

When changing the filter element a detachable connection between the filter head and the filter bowl prevents a flow back of dirty oil into the tank.

4. Technical data:

temperature range:	- 10 °C to + 80 °C (for a short time + 100 °C)
operating medium:	mineral oil, other media on request
max. operating pressure:	10 bar
opening pressure by-pass valve:	2,5 bar
opening pressure preload valve:	0,5 bar
opening pressure suction valve:	0,05 bar
line adapter:	SAE 2" and SAE 1 1/2"
housing material:	Al-casting, polyamide 6
sealing material:	Nitrile (NBR) or Viton (FPM), other materials on request
installation position:	vertical
volume tank:	3,7 l

Classified under the Pressure Equipment Directive 97/23/EC for mineral oil (fluid group 2), Article 3, Para. 3.

Classified under ATEX Directive 94/9/EC according to specific application (see questionnaire sheet-no. 34279-4).

5. Symbols:

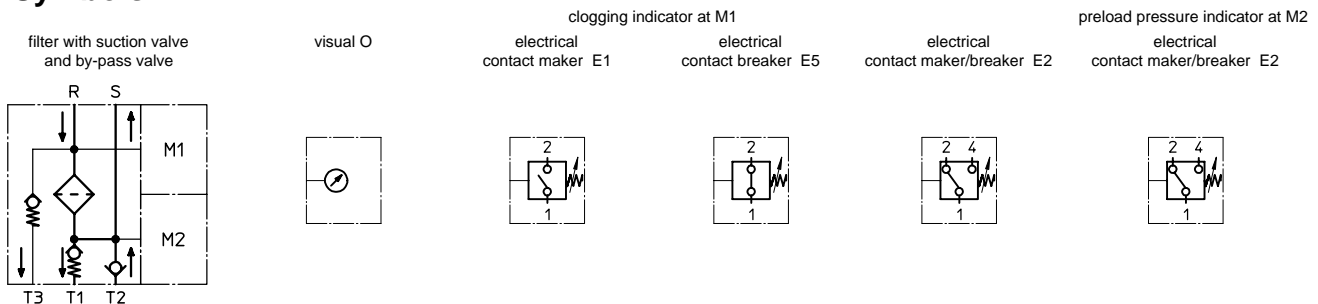

6. Pressure drop flow curves:

Precise flow rates see 'INT-Expert-System Filter' respectively Δp -curves; depending on filter fineness and viscosity.

7. Test methods:

Filter elements are tested according to the following ISO standards:

- ISO 2941 Verification of collapse/burst resistance
- ISO 2942 Verification of fabrication integrity
- ISO 2943 Verification of material compatibility with fluids
- ISO 3723 Method for end load test
- ISO 3724 Verification of flow fatigue characteristi
- ISO 3968 Evaluation of pressure drop versus flow characteristics
- ISO 16889 Multi-pass method for evaluating filtration performance