

Proportional relief valves type RZMO

direct operated, ISO 4401 size 06

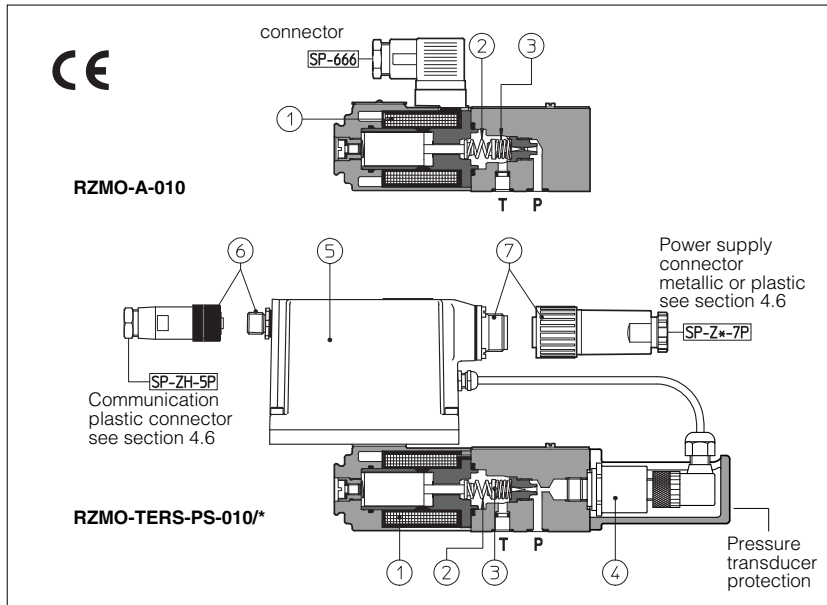

RZMO are poppet type proportional pressure relief valves, direct operated with pressure regulation proportional to electronic reference signals.

They operate in association with electronic drivers, see table 8, which supply the proportional valve with proper current to align valve regulation to the reference signal supplied to the electronic driver.

They are available in different executions:

- -A, without integral pressure transducer.
- -AE, -AES, as -A plus analogue (AE) or digital (AES) integral electronics ⑤.
- -TERS with integral pressure transducer ④ plus digital electronics ⑤ preset in closed loop, featuring improved static and dynamic performances.
- -AERS as -TERS but without integral pressure transducer (predisposed for connection of remote pressure transducer).

The system pressure is controlled by the poppet ③, directly operated by the proportional solenoid ① and the spring ②.

The integral electronics ensures factory presetting, fine functionality plus valve-to-valve interchangeability and simplified wiring and installation.

Following communication interfaces ⑥ are available for the -AES, -TERS and -AERS executions:

- -PS, RS232 serial communication interface. The valve reference signal is provided with analogue commands via the 7 (or 12) pins connector ⑦.
 - -BC, CANbus interface
 - -BP, PROFIBUS-DP interface
- In the -BC and -BP interfaces the valve reference signal is provided via fieldbus. During start up or maintenance, the valves can be operated with analogue signals via the 7 (or 12) pins connector ⑦.

The coils are fully plastic encapsulated (insulation class H), and the valves have antivibration, antishock and weather-proof features.

Mounting surface: ISO 4401, size 06

Max flow: 4 l/min

Max pressure: 315 bar.

1 MODEL CODE

RZMO - TERS - PS - 010 / 315 / * ** / *

Proportional pressure relief valves size 06					Synthetic fluids WG = water-glycol PE = phosphate ester
A = without integral transducer					Series number
AE = as A plus integral electronics					
AES = as A plus integral digital electronics					
TERS = with integral digital electronics and pressure transducer					
AERS = as TERS but with remote pressure transducer (to be ordered separately, see tab. G460)					
Communication interfaces (only for AES, TERS and AERS)					
PS = RS232 serial					
BC = CANbus					
BP = PROFIBUS-DP					
Configuration:					
0 = size 06	10 = P and T ports				
Pressure range:					
50 = 50 bar (not for -TERS and -AERS)	210 = 210 bar				
100 = 100 bar	315 = 315 bar				

Options, see section 4:
for -A execution:
6 = with 6 V_{DC} coil instead of standard 12V_{DC} coil
18 = with 18 V_{DC} coil instead of standard 12V_{DC} coil
for -AE execution:
I = current reference (4±20 mA)
Q = enable signal
for -AES, -TERS and -AERS executions:
I = current reference 4±20 mA (only for TERS execution)
Z = double power supply, enable and fault (12 pin connector)
C = remote pressure transducer with current feedback 4±20 mA (only for AERS execution)

2 HYDRAULIC CHARACTERISTICS (based on mineral oil ISO VG 46 at 50 °C)

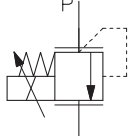
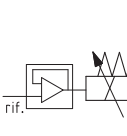
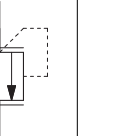
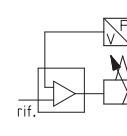
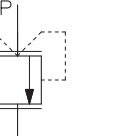
Hydraulic symbols					
Valve model	RZMO-A	RZMO-AE	RZMO-AES	RZMO-TERS	RZMO-AERS
Max regulated pressure (Q = 1 l/min) [bar]	50	100	210	315	100
Min. regulated pressure (Q = 1 l/min) [bar]	1	1,8	2,5	3,5	1,8
Max. pressure at port P [bar]	315				
Max. pressure at port T [bar]	210				
Max. flow [l/min]	4				
Response time 0-100% step signal (depending on installation) - see section 6.4 [ms]	≤70			≤55	
Hysteresis [% of the max pressure]	≤1,5			≤0,3	
Linearity [% of the max pressure]	≤3			≤1,0	
Repeatability [% of the max pressure]	≤2			≤0,2	
Thermal drift (-TERS execution)	zero point displacement < 1% at ΔT = 40°C				

Above performance data refer to valves coupled with Atos electronic drivers, see section 8.

3 MAIN CHARACTERISTICS OF PROPORTIONAL PRESSURE RELIEF VALVES TYPE RZMO

Assembly position	Any position
Subplate surface finishing	Roughness index, \sqrt{Ra} flatness ratio 0,01/100 (ISO 1101)
Ambient temperature	-20°C ÷ +70°C for -A execution; -20°C ÷ +60°C for -AE and -AES; -20°C ÷ +50°C for -TERS and -AERS
Fluid	Hydraulic oil as per DIN 51524 ... 535 for other fluids see section 3
Recommended viscosity	15 ÷ 100 mm ² /s at 40°C (ISO VG 15÷100)
Fluid contamination class	ISO 18/15 achieved with in line filters of 10 µm and $\beta_{10} \geq 5$ (recommended)
Fluid temperature	-20°C +60°C (standard and /WG seals) -20°C +80°C (/PE seals)

3.1 Electrical characteristics

Coil resistance R at 20°C	3 ÷ 3,3 Ω for standard 12 V _{dc} coil; 2 ÷ 2,2 Ω for 6 V _{dc} coil; 13 ÷ 13,4 Ω for 18 V _{dc} coil
Max solenoid current	2,6 A for standard 12 V _{dc} coil; 3,25 A for 6 V _{dc} coil; 1,5 A for 18 V _{dc} coil
Max power	40 Watt
Protection degree (CEI EN-60529)	IP65 for -A execution; IP65÷67 for -AE, -TERS and AERS executions, depending to the connector type (see sect. 4.6)
Duty factor	Continuous rating (ED=100%)

4 INTEGRAL ELECTRONICS OPTIONS AND WIRING

4.1 Option /I

It provides the 4÷20 mA current reference signal and the current monitor signal instead of the standard 0÷10 V. It is normally used in case of long distance between the machine control unit and the valve or where the reference signal can be affected by electrical noise. In case of breakage of the reference signal cable, the valve functioning is disabled.

4.2 Option /Q

Safety option providing the possibility to enable or disable the valve functioning without cutting the power supply.

4.3 Option /Z

Safety option, specifically introduced for -BC and -BP communication interfaces, provides two separated electric power supplies for the digital electronic circuits and for the solenoid power supply stage. The Enable and Fault signals are also available. The option /Z allows to interrupt the valve functioning by cutting the solenoid power supply (e.g. for emergency, as provided by the European Norms EN954-1 for components with safety class 2), but keeping energized the digital electronic circuits, thus avoiding fault conditions of the machine fieldbus controller.

For the electrical wiring, see tab. G115 and G205.

4.4 Option /C

The valve electronics is set to receive the 4÷20 mA feedback signal from the remote pressure transducer, instead of the standard 0÷10 V.

4.5 Integral electronics wiring

For the electric wiring shielded cables must be provided: the shield must be connected to the power supply zero **on the generator side**, see tab. F003

POWER SUPPLY CONNECTOR				
PIN	SIGNAL DESCRIPTION	-AE, -AES, -TERS, -AERS	-AE/I, -TERS/I, -AERS/I	-AE/Q
A	Power supply 24 V _{dc}	Stabilized: +24V _{dc}		
B	Power supply zero	Filtered and rectified: V _{rms} = 21 ÷ 33 (ripple max 2V _{pp})		
C	Signal zero	Reference 0 V _{dc}	Reference 0 V _{dc}	Enabling input normal working 9 ÷ 24 V _{dc}
D	Input signal +			
E	Input signal -	0 ÷ 10 V _{dc}	4 ÷ 20 mA	0 ÷ 10 V
F	Monitor driving current (for -AE, -AES) regulated pressure (for -TERS, -AERS)	0 ÷ 10 V referred to pin C (signal 0 V _{dc}) 1V = 1A 1V = 10% of regulated pressure	0 ÷ 5 V (-AE/I) 4 ÷ 20 mA (-TERS/I) 1V = 1A 4 ÷ 20 mA = 0÷100% of regulated pressure	0 ÷ 5 V referred to pin B (signal 0 V _{dc}) 1V = 1A -
G	Earth	Connect only when the power supply is not conform to VDE 0551 (CEI 14/6)		

COMMUNICATION INTERFACE CONNECTORS (-AES, -TERS, -AERS)				
Communication options	-PS (RS232) male connector	-BC (CAN Bus) male connector	-BP (PROFIBUS-DP) female connector (reverse key)	
Pin number Signal description	1	NC	CAN_SHLD	+5V
		Not Connected	Shield	Termination voltage
	2	NC	NC	LINE -A
		Not Connected	Not Connected	Bus line (high)
	3	RS_GND	CAN_GND	DGND Signal zero data line
	Signal zero data line	Signal zero data line	/ termination voltage	
4	RS_RX	CAN_H	LINE-B	Bus line (low)
	Valves receiving data line	Bus line (high)	SHIELD	Shield
5	RS_TX	CAN_L		
	Valves transmitting data line	Bus line (low)		

PRESSURE TRANSDUCER CONNECTOR (-AERS) see section 3		
PIN	standard version	option /C
1	Pressure signal	Pressure signal
2	Reserved (do not connect)	Reserved (do not connect)
3	Power supply	Power supply
4	GND	Reserved (do not connect)

Note:

- electrical signals (e.g. feedback signals) processed by valve electronics must not be used to switch off the machine safety functions. This is in accordance with the European standards (Safety requirements of fluid technology systems and components - hydraulics, EN 982).
- installation notes with basic information for commissioning and start-up are always supplied with the relevant components, together with the specific technical tables.

4.6 Model codes of power supply and communication connectors

VALVE VERSION	-A	-AE, -AES, -TERS, -AERS	-AES/Z, -TERS/Z, -AERS/Z	-RS232 (-PS) OR CANBUS (-BC)	PROFIBUS (-BP)	PRESSURE TRANSDUCER only for AERS
CONNECTOR CODE	SP-666	SP-ZH-7P (1)	SP-ZM-7P (1)	SP-ZH-12P (1)	SP-ZH-5P (1)	SP-ZH-4P-M8/5 (1)(2)
PROTECTION DEGREE	IP65	IP67	IP67	IP65	IP67	IP67

(1) to be ordered separately (2) M8 connector moulded on cable 5 mt lenght

5 PROGRAMMING DEVICES

The functional parameters of the digital valves, as the bias, scale, ramp and linearization of the regulation characteristic, can be easily set and optimized with graphic interface by using the following software programming devices suitable for standard PC:

KIT-E-SW-PS for electronics with RS232 interface (option -PS)

KIT-E-SW-PS-TERS only for -TERS-PS electronics - simplified version of KIT-E-SW-PS with only bias and scale settings.

KIT-E-SW-PS-TERS/U as KIT-E-SW-PS-TERS with serial to USB interface

KIT-E-SW-BC for electronics with CANbus interface (option -BC)

KIT-E-SW-BP for electronics with PROFIBUS-DP interface (option -BP)

see tab. G500 for complete information about the programming device kits and for the PC minimum requirements.

Only for the -BC and -BP communication options, the functional parameters can be alternatively set via fieldbus through the machine control unit, using the standard communication protocol implemented by Atos.

The protocol operating instructions to be implemented in the standard protocols (DS301V4.02, DSP408 for CANbus and DPVO for PROFIBUS-DP) are described in the user manuals MAN-S-BC (for -BC option) and MAN-S-BP (for -BP option) supplied with the relevant programming device kits.

The above programming devices have to be ordered separately.

6 DIAGRAMS (based on mineral oil ISO VG 46 at 50 °C)

6.1 Regulation diagrams

with flow rate $Q = 1 \text{ l/min}$

1 = RZMO-A, RZMO-AE, RZMO-AES

2 = RZMO-TERS, RZMO-AERS

Notes:

- 1) For the valves with digital electronics, the regulation characteristic can be modified by setting the internal software parameters, see tab. G500.
- 2) For executions -A, -AE and -AES the presence of counter pressure at port T can alter the effective pressure regulation.

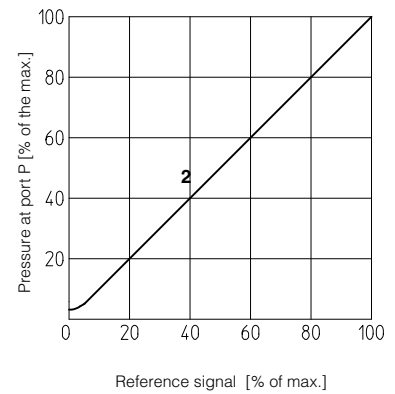
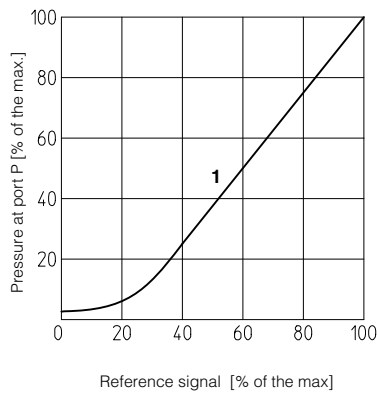

6.2 Pressure/flow diagrams

with reference signal set at $Q = 1 \text{ l/min}$

3 = RZMO-A, RZMO-AE, RZMO-AES

4 = RZMO-TERS, RZMO-AERS

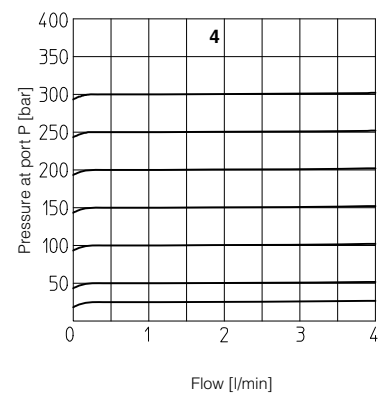
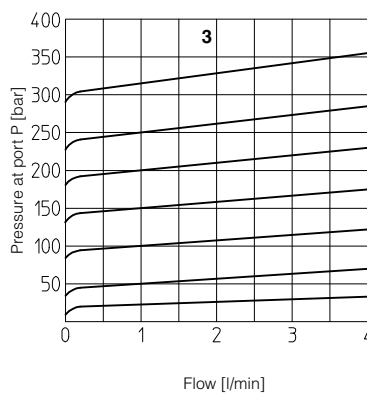

6.3 Min. pressure/flow diagrams

with reference signal "null"

5 = RZMO-*-010/50

6 = RZMO-*-010/100

7 = RZMO-*-010/210

8 = RZMO-*-010/315

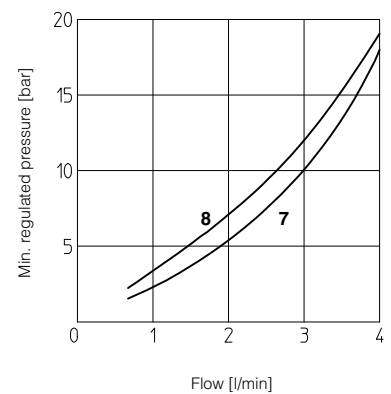
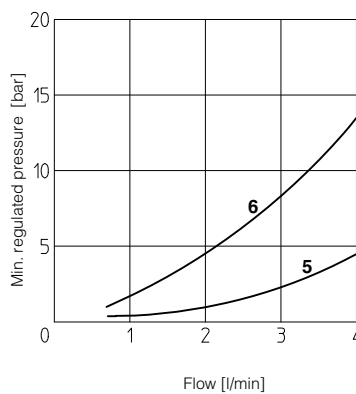

6.4 Dynamic response

The response times in section 2 have to be considered as average values.

The integral closed loop control of -TERS and -AERS valves is affected by the stiffness of the hydraulic circuit: greater is the stiffness of the circuit, the better are the performances. The valves dynamic performances can be optimized depending on the stiffness characteristics of the hydraulic circuit, by setting the internal software parameters. This regulation is particularly helpful in case of circuits with accumulators and/or with great fluid volumes and/or with long hoses.

7 INSTALLATION DIMENSIONS [mm]

ISO 4401: 2005

**Mounting surface: 4401-03-02-0-05
(without ports A and B)**

Fastening bolts:
4 socket head screws M5X50 class 12.9
Tightening torque = 8 Nm
Seals: 2 OR 108
Ports P, T: $\varnothing = 5$ mm

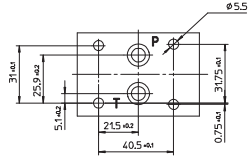

valve's surface

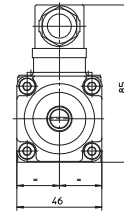
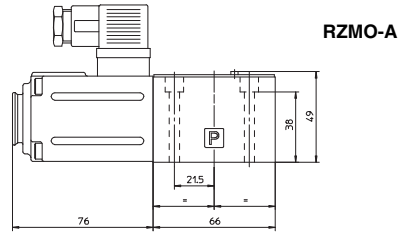

Mass: 1,8 Kg

**RZMO-AE
RZMO-AES-***
(dotted line)

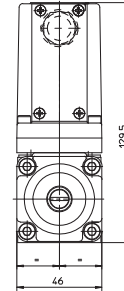
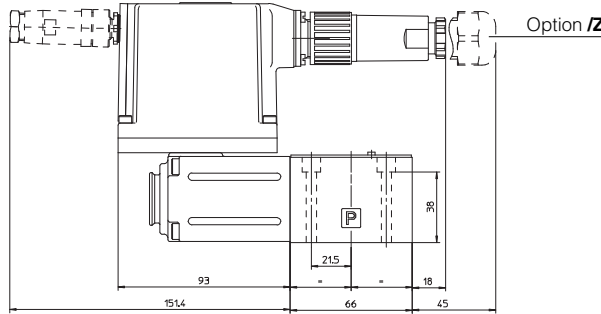

Mass: 2,4 Kg

RZMO-TERS-*

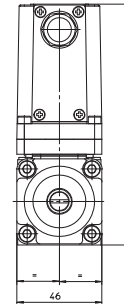
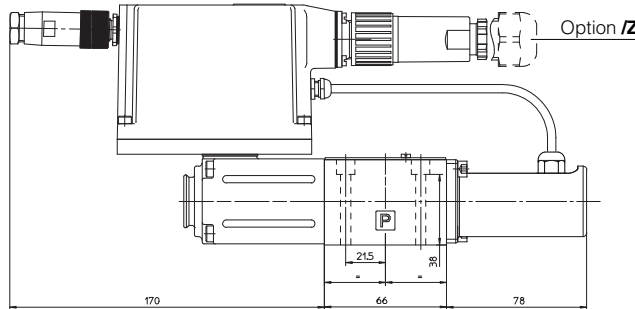

Mass: 2,7 Kg

RZMO-AERS-*

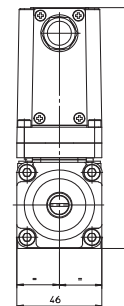
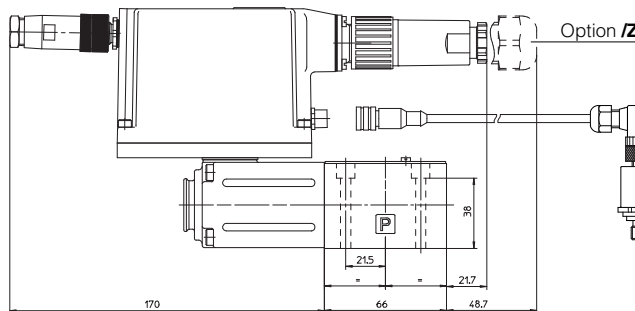

Mass: 2,5 Kg

8 ELECTRONIC DRIVERS FOR RZMO

Valve model	-A				-AE	-AES	-TERS	-AERS
Drivers model	E-MI-AC-01F	E-BM-AC-01F	E-ME-AC-01F	E-RP-AC-01F	E-RI-AE	E-RI-AES	E-RI-TERS	E-RI-AERS
Data sheet	G010	G025	G035	G100	G110	G115	G205	

For complete information about the drivers characteristics and relevant options, see the technical data sheet specified in the table.

9 MOUNTING PLATES

Model	Ports location	Gas ports A-B-P-T	\varnothing Counterbore [mm] A-B-P-T	Mass [kg]
BA-202	Ports A, B, P, T underneath	3/8"	-	1,2
BA-204	Ports P, T underneath; Ports A, B on lateral side	3/8"	25,5	1,8
BA-302	Ports A, B, P, T underneath	1/2"	30	1,8

The subplates are supplied with 4 fastening bolts M5X50. For further details see table K280