

PRESSURE FILTER

Series LF 63 DN 20 PN 25

Sheet No.
1109 G

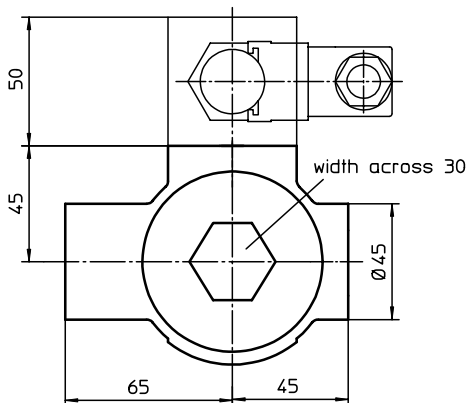
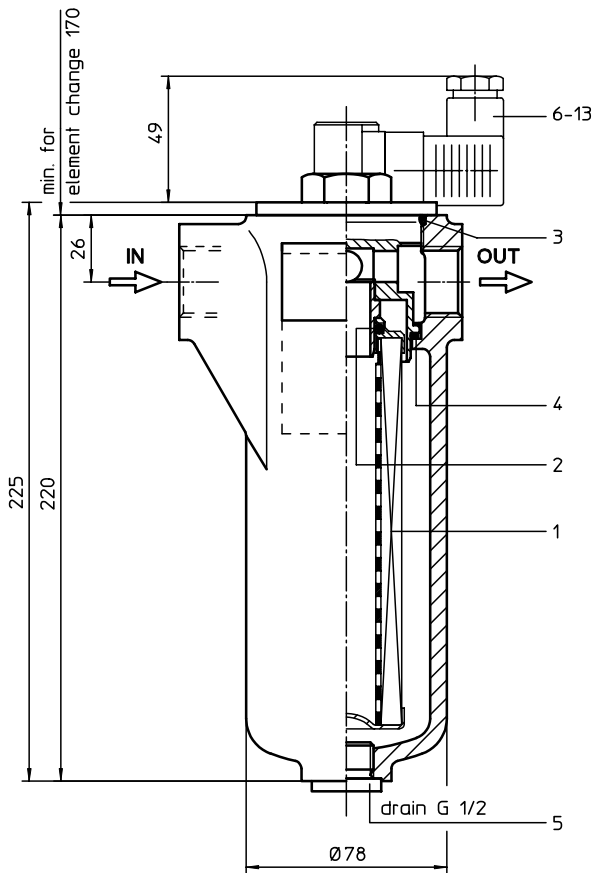

1. Type index:

1.1. Complete filter: (ordering example)

LF. 63. 10VG. 30. E. P. -. G. 4. -. -. AE

1	2	3	4	5	6	7	8	9	10	11	12
---	---	---	---	---	---	---	---	---	----	----	----

- 1 **series:**
LF = in-line filter
- 2 **nominal size:** 63
- 3 **filter-material and filter-fineness:**
80 G = 80 μm , 40 G = 40 μm , 25 G = 25 μm
stainless steel wire mesh
25 VG = 20 $\mu\text{m}_{(c)}$, 16 VG = 15 $\mu\text{m}_{(c)}$, 10 VG = 10 $\mu\text{m}_{(c)}$,
6 VG = 7 $\mu\text{m}_{(c)}$, 3 VG = 5 $\mu\text{m}_{(c)}$ Interpor fleece (glass fibre)
- 4 **resistance of pressure difference for filter element:**
30 = Δp 30 bar
- 5 **filter element design:**
E = single-end open
- 6 **sealing material:**
P = Nitrile (NBR)
V = Viton (FPM)
- 7 **filter element specification:** (see catalog)
- = standard
VA = stainless steel
IS06 = see sheet-no. 31601
IS07 = see sheet-no. 31602
- 8 **connection:**
G = thread connection according to DIN 3852, T2
- 9 **connection size:**
4 = G $\frac{3}{4}$
- 10 **filter housing specification:** (see catalog)
- = standard
IS06 = see sheet-no. 31605
- 11 **internal valve**
- = without
S1 = with by-pass valve Δp 3,5 bar
- 12 **clogging indicator or clogging sensor :**
- = without
AOR = visual, see sheet-no. 1606
AOC = visual, see sheet-no. 1606
AE = visual-electrical, see sheet-no. 1615
VS1 = electrical, see sheet-no. 1617
VS2 = electrical, see sheet-no. 1618

1.2. Filter element: (ordering example)

01NL. 63. 10VG. 30. E. P. -

1	2	3	4	5	6	7
---	---	---	---	---	---	---

- 1 **series:**
01NL. = standard filter element according to DIN 24550, T3
- 2 **nominal size:** 63
- 3 - 7 | see type index-complete filter

weight: 2,0 kg

Changes of measures and design are subject to alteration!

EDV 11/07

internormen
technology

Friedensstrasse 41, 68804 Altlussheim, Germany

phone +49 - (0)6205 - 2094-0
fax +49 - (0)6205 - 2094-40

e-mail sales@internormen.com
url www.internormen.com



2. Spare parts:

item	qty.	designation	dimension	article-no.	
1	1	filter element	01NL 63		
2	1	O-ring	22 x 3,5	304341 (NBR)	304392 (FPM)
3	1	O-ring	56 x 3	305072 (NBR)	305322 (FPM)
4	1	O-ring	48 x 3	304357 (NBR)	304404 (FPM)
5	1	screw plug	G ½	304678	
6	1	clogging indicator, visual	AOR or AOC	see sheet-no. 1606	
7	1	clogging indicator, visual-electrical	AE	see sheet-no. 1615	
8	1	clogging sensor, electrical	VS1	see sheet-no. 1617	
9	1	clogging sensor, electrical	VS2	see sheet-no. 1618	
10	1	O-ring	15 x 1,5	315357 (NBR)	315427 (FPM)
11	1	O-ring	22 x 2	304708 (NBR)	304721 (FPM)
12	1	O-ring	14 x 2	304342 (NBR)	304722 (FPM)
13	2	screw plug	G 7/8	305496	

item 13 execution only without clogging indicator or clogging sensor

3. Description:

In-line filters of the type LF 63 are suitable for a working pressure up to 25 bar.

Pressure peaks are absorbed with a sufficient margin of safety.

The filter is mounted in such a way that inlet and outlet are on the same level. It can be used as suction filter, pressure filter and return-line filter. The filter element consist of star-shaped, pleated filter material which is supported on the inside by a perforated core tube and is bonded to the end caps with a high-quality adhesive. The flow direction is from outside to the inside.

The particles are hold back on the outside. For cleaning (see special leaflet 21070-4) the mesh element respectively to change the glass fiber element remove the cover and take out the element.

Filter finer than 40 µm should use throw-away elements made of paper or Interpor fleece (glass fibre). Filter elements as fine as 5 µm_(c) are available; finer filter elements on request.

INTERNORMEN-Filter elements are known as elements with a high intrinsic stability and an excellent filtration capability, a high dirt-retaining capacity and a long service life.

INTERNORMEN-Filter are suitable for all petroleum based fluids, HW-emulsions, most synthetic hydraulic fluids and lubrication oils. Approvals according to TÜV, and the major „Shipyards Classification Societies“ D.N.V.; B.V.; G.L.; L.R.S.; R.I.N.A.; A.B.S. and others are possible.

The internal valve is integrated in the filter cover.

After reaching the opening pressure the by-pass valve causes that an unfiltered partial flow passes the filter.

4. Technical data:

temperature range:	-10°C bis +80°C (for a short time +100°C)
operating medium:	mineral oil, other media on request
max. operating pressure:	25 bar
test pressure:	33 bar
connection system:	thread connection according to DIN 3852, T2
housing material:	aluminium-cast
sealing material:	Nitrile (NBR) or Viton (FPM), other materials on request
installation position:	vertical
mini-measuring connection:	G ¼
evacuation-or bleeder-connection:	G ½
volume tank:	0,7 l

Classified under the Pressure Equipment Directive 97/23/EC for mineral oil (fluid group 2), Article 3, Para. 3.

Classified under ATEX Directive 94/9/EC according to specific application (see questionnaire sheet-no. 34279-4).

5. Symbols:

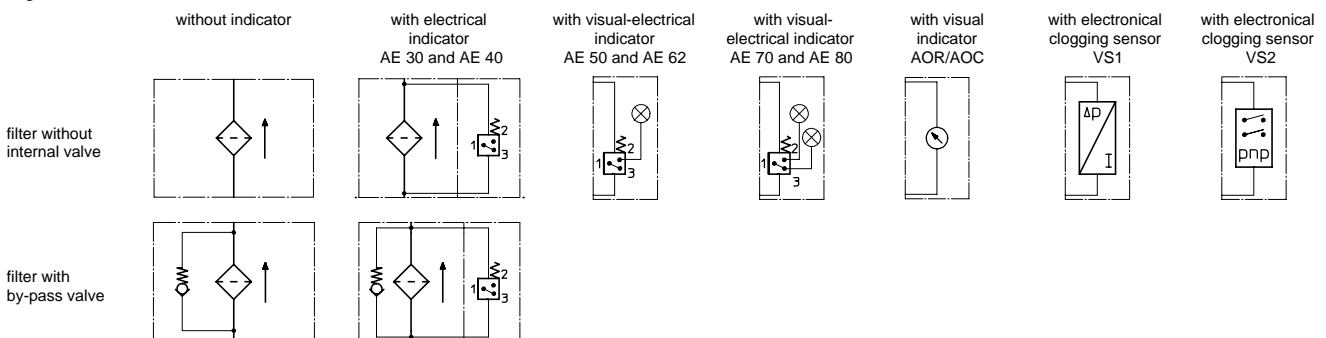

6. Pressure drop flow curves: Precise flow rates see 'INT-Expert-System Filter', respectively Δp -curves ; depending on filter fineness and viscosity.

7. Test methods:

Filter elements are tested according to the following ISO standards:

ISO 2941	Verification of collapse/burst resistance
ISO 2942	Verification of fabrication integrity
ISO 2943	Verification of material compatibility with fluids
ISO 3723	Method for end load test
ISO 3724	Verification of flow fatigue characteristics
ISO 3968	Evaluation of pressure drop versus flow characteristics
ISO 16889	Multi-pass method for evaluating filtration performance