

G3/G3A + F10

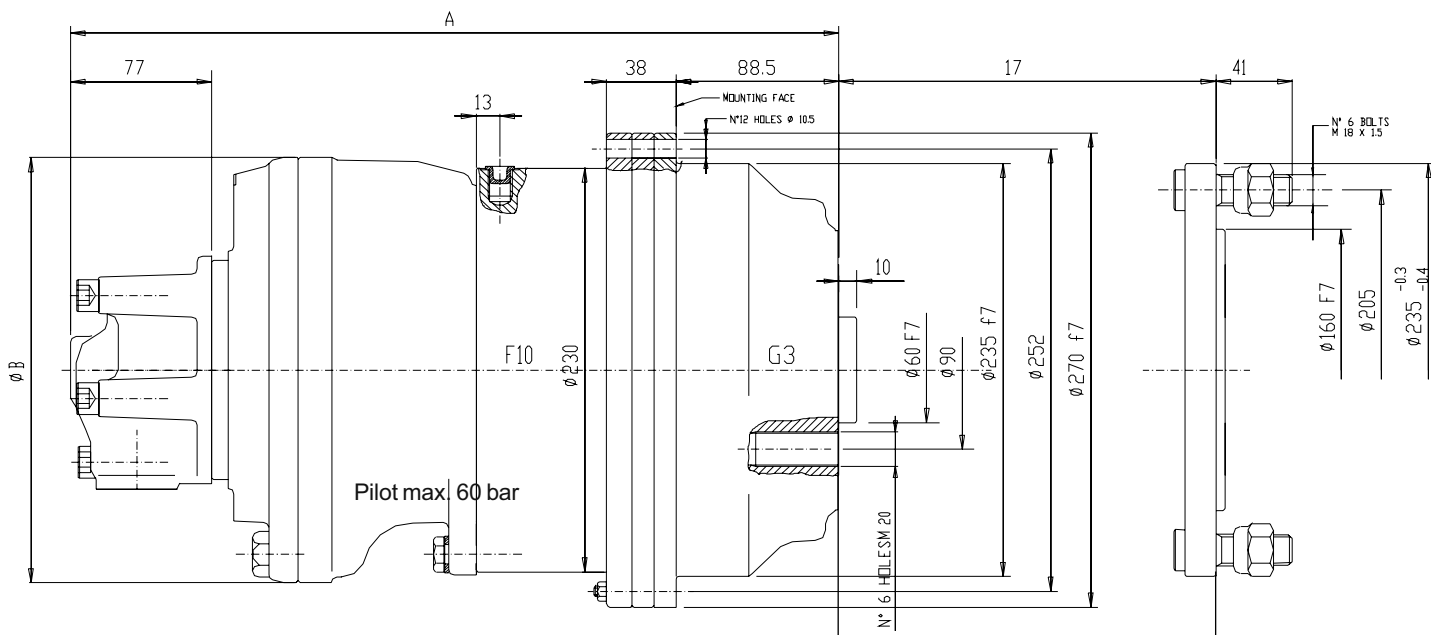

G3/G3A + F10		G3	G3A
Reduction rate / Rapporto di riduzione		1:7	1:5
Peak torque / Coppia di picco	Nm	7000	10000
Max. continuous torque / Coppia continua max.	Nm	3500	5000
Peak speed / Velocità di picco	rpm	200	300
Peak power / Potenza di picco	kW	50	50
Weight (only gearbox) / Peso (solo riduttore)	kg	20	20
Weight (with brake) / Peso (con freno)	kg	32	32



DIMENSIONI	A	A	B
DIMENSIONI	(G3/G3A)	(G3/G3A+F10)	Ø
GM05	337.5	413.5	205
GM1, BD1	340.5	418.5	242
GM2, BD2	383.5	463.5	300

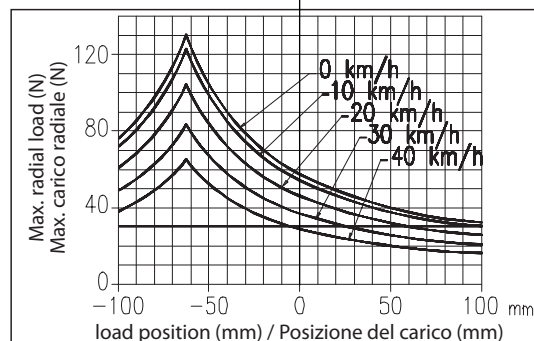

SPECIAL SHAFT SEAL

ANELLO DI TENUTA SPECIALE

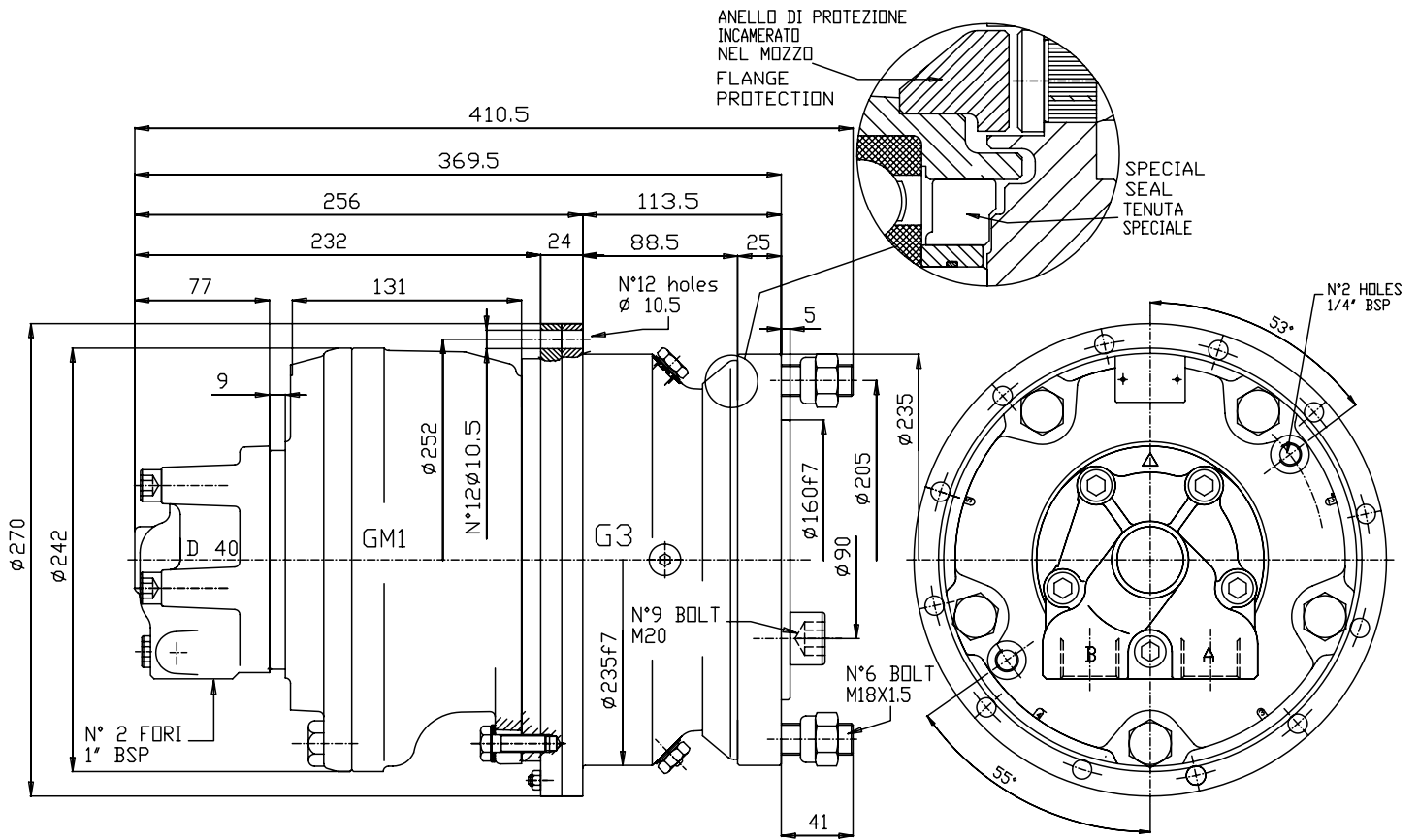

VERSION C: \varnothing 300mm

Versione C: FLANGIA \varnothing 300mm

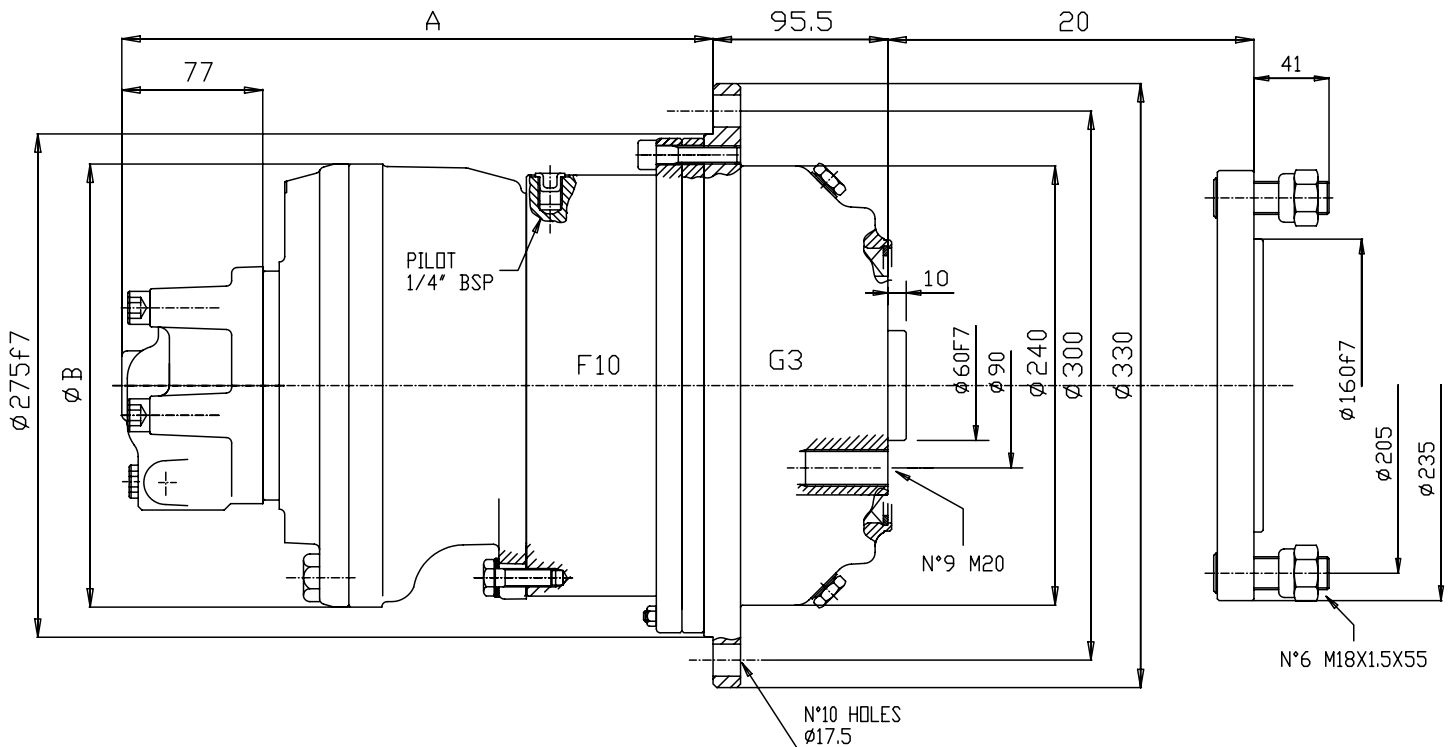

G3/G3A + F10

Braking torque in function of the number of brake disc springs.

The standard version is supplied with 19 springs.

Coppia frenante in funzione del numero di molle spingi disco.

La versione standard viene fornita con 19 molle.

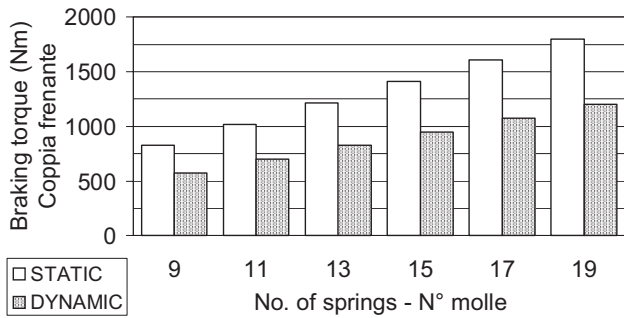

Opening pressure
Pressione di apertura

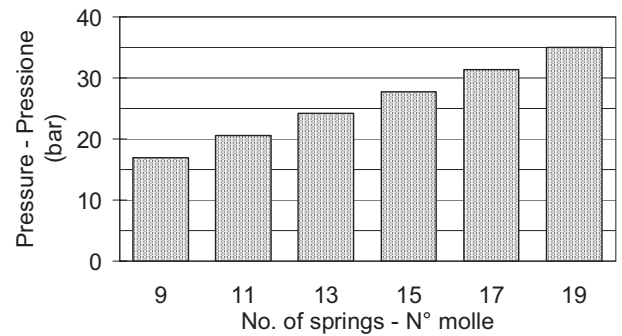

ORDERING / ORDINAZIONE

G3 / G3A Gearbox / Riduttore

C Version with Ø300 flange / versione con flangia Ø300

F10 Brake / Freno

9..19 N. of brake springs / N. molle nel freno

O With gearbox breather valve for separate motor casing and gearbox (and brake) oil
Con valvola di sfiato per motore e riduttore (e freno) con olio separato

U Shared motor casing and gearbox (and brake) oil
Motore e riduttore (e freno) con olio unico

0,1,2 Motor size (0 - for GM05, 1 - for GM1, BD1, 2 - for GM2, BD2)
Tipo motore (0 - per GM05, 1 - per GM1, BD1, 2 - per GM2, BD2)

31/A Hub 31/A for G3,G3A / Mozzo 31/A per G3, G3A

31/B Hub 31/B for G3C,G3AC / Mozzo 31/B per G3C, G3AC

31/D Hub 31/D for special shaft seal
Mozzo 31/D per anello di tenuta speciale

