

# ABF

## Fully Automatic Backflushing Filter Manual and maintenance instructions

CE 2001



### *Operating and maintenance instructions* Version 1.0

Serial-No.: .....

Version-/Rev.-Date: 06.11.2009

**INTERNORMEN Technology GmbH**  
Friedensstr. 41  
Germany – 68804 Altlußheim  
Tel. +49 (0) 6205 – 2094 - 0

e-mail: [info@internormen.com](mailto:info@internormen.com)  
<http://www.internormen.com>  
FAX +49 (0) 6205 – 2094 - 40

# INDEX

	Page
<b>GENERAL</b>	<b>3</b>
<b><u>1. SAFETY INSTRUCTIONS</u></b>	<b><u>3</u></b>
<b><u>2. INSTALLATION</u></b>	<b><u>4</u></b>
<b><u>3. OPERATION AND APPLICATION</u></b>	<b><u>5</u></b>
3.1 Connection Diagram	7
3.2 Remote Control	9
<b><u>4. MAINTENANCE</u></b>	<b><u>9</u></b>
<b><u>5. CHANGE OF INNER PARTS AND ELEMENTS</u></b>	<b><u>9</u></b>
<b><u>6. ASSEMBLY</u></b>	<b><u>10</u></b>
<b><u>7. ANNEX</u></b>	<b><u>12</u></b>

## Operating and maintenance instructions

### Backflushing filters

This manual is effective for all backflushing filters of the series ABF 50-1000 and specifications related to this filter series. It contains certain requirements and instructions which ensure a flawless operation of the filter. The manual can be completed with specific additional instructions by the operator if necessary. The above mentioned pressure filters are designed for liquid filtration.

#### **General**

The backflushing filter .... is a fully automatic self-cleaning system designed to extract particles from low-viscosity fluids. This system is designed for filtration of high volume flow-rates through a considerably small filter, assuring operational reliability and reducing operating and maintenance costs.

The filtration and highly effective separation of contaminating particles from the process medium, is constantly assured by the slotted-tube filter elements. The fluid flows from the inside to the outside, while the backflushing is made from the outside to the inside by means of a rotating arm. The pressure drop between the filter side and the backflushing line flushes a small part of the filtrate backwards to the filter elements to be cleaned. The contamination particles collected on the inside of the filter elements are loosened and flushed into the backflushing line via the flushing arm.

#### **1. Safety instructions**

- Prior to operating the filter, the manual and maintenance instructions have to be read carefully.
- The instructions given in this manual have to be strictly followed!
- The manufacturer does not assume liability for any damage, which occurs due to disregarding these instructions.
- If operations are carried out differently, the safety of the pressurized device cannot be assured!
- Operating conditions given in the data sheet, especially excess pressure, temperature range and operating fluid, have to be followed strictly. Variation within these parameters can cause damage to important pressure holding parts and sealing. The compatibility of the filter components with the operating fluid have to be considered as well.
- Under working conditions the filter housing is pressurized. Do not try to loosen or remove any part of the filter or the filter housing during operation. The operating fluid can leak under high pressure and high temperatures.
- Leaking operating fluid always bears the danger of injuries and burns!
- Do not open the filter housing until you made sure it is not pressurized anymore!
- Touching parts of the filter may cause burns, depending on the operating temperature.
- Always wear safety goggles and gloves when working on the filter!
- If you come into contact with the operating fluid please follow the instructions of the fluid manufacturer!!

***Use only original spare parts.***

## 2. Installation

The filter is supplied and delivered ready for installation. The fitting position of the filter is vertical. The filter has to be fitted with fastening screws of size and amount according to the corresponding fastening bore holes of the filter housing. The fitting of the filter has to be carried out in the way that the least possible transmission of tensile forces on the filter housing and the purge valve is given. The connection of the pipework has to be made with flanges for pipework.

While assembling ensure that:

- No dirt and no impurities or foreign fluids permeate the filter
- The connections for input "A" and output "B" are correctly connected to the pipe system

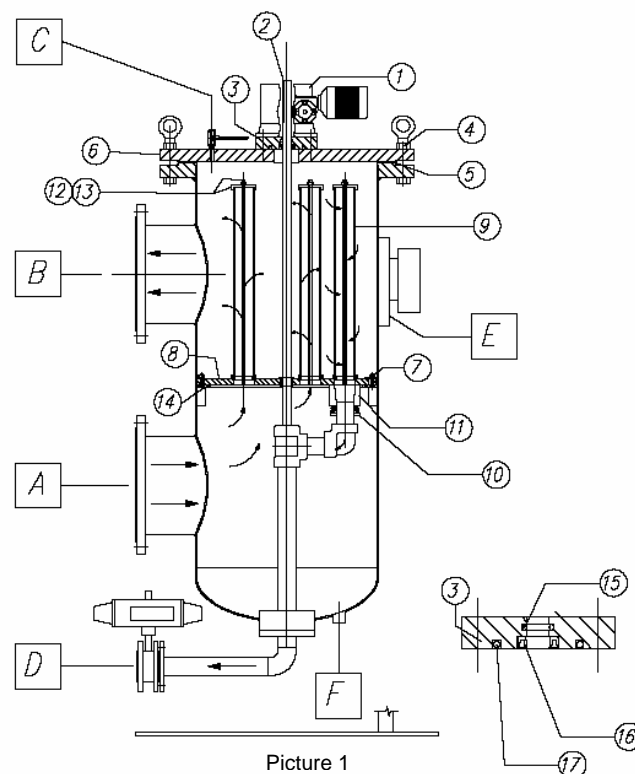

Picture 1

- The connection of the purge valve "C" doesn't create counter pressure (the minimum pressure drop of the inner fluid and discharge pipe must be 2 bar)
- The pipe system is connected with the filter; as stress-free as possible
- The height necessary for demounting and the accessibility of service elements are guaranteed
- Where required, the air pressure supply (6..8 bar) is connected to the purge valve "D"
- The power supply has to be installed according to the unit specific conditions and according to the technical parameters of the corresponding data sheets.

**Pay attention that the motor turns clockwise**

**3. Operation and application**

The power supply is indicated by the light “L(x)-1”.

The filtrate flow is not being interrupted during the backflushing cycle.

The backflushing cycle starts automatically:

- when the pressure drop of the pressure switch “PS” set value of 0,45 bar (adjustable) is reached and the contact points “PS4-1” (10-11) close down
- by means of an adjustable timer “KT4-1”
- when the test key “P4-2” is pressed

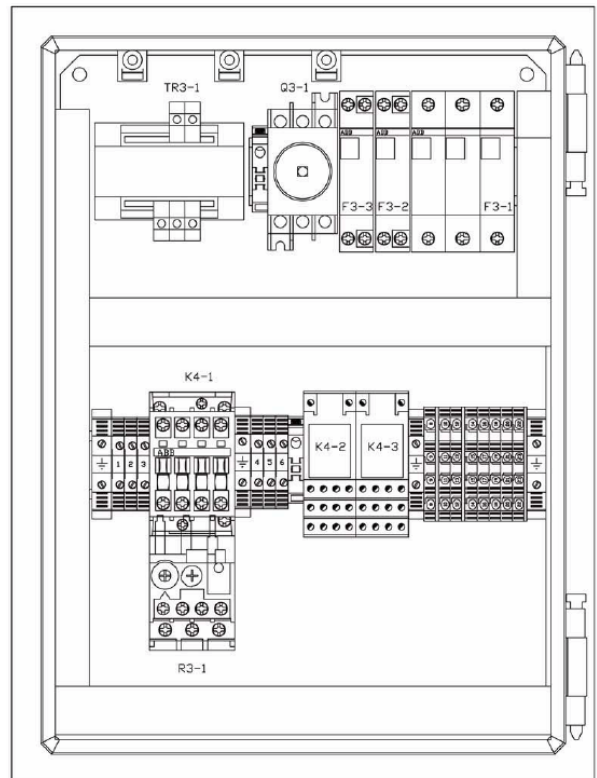
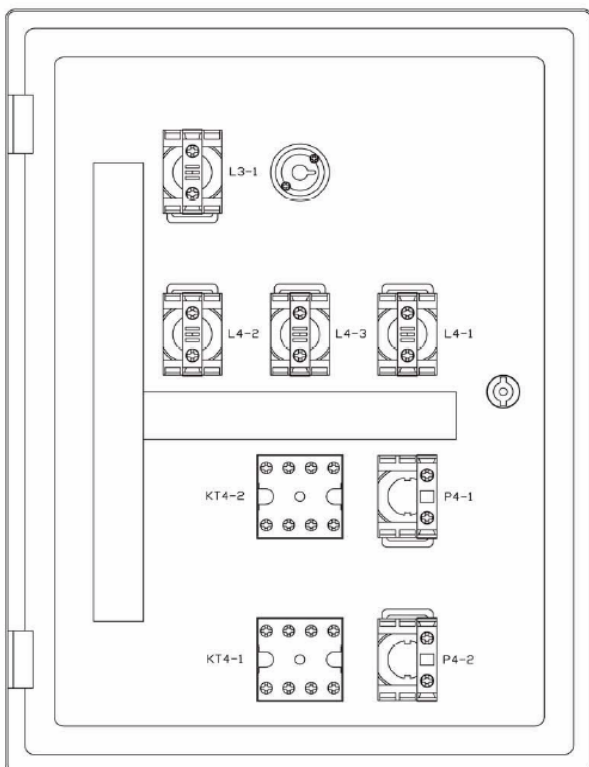
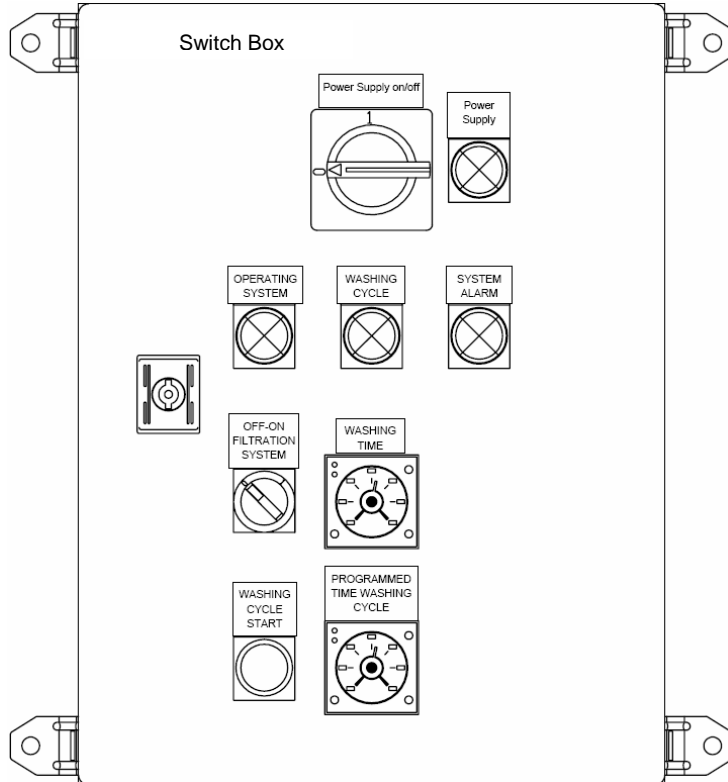

When one of these events occurs, the relay “K4” is being excited and through the contact “K4-1”, the timer “KT4-2” starts to run the electrical geared motor “MR”, which turns the flushing arm under the filter elements to be cleaned, and the backflushing valve “D” is being opened operated by the solenoid “EV4-1”. The pressure drop between filter side and backflushing line flushes a small part of the filtrate backwards into the filter elements to be cleaned. The contamination particles collected on the inside of the filter elements are loosened and flushed into the backflushing line via the flushing arm. All the filter elements are being individually flushed (in succession). The light “L4-2” indicates that this operation is running.

The backflushing cycle is finished after the time set for backflushing on the device “KT4-2” is expired and the pressure drop of the pressure switch “PS” is lower than the set value. The time suggested for one backflushing cycle is 120 seconds. The operator can change the time, according to his needs. The geared motor “MR” stops turning and the purge valve “D” shuts down (*Picture 1*). If the contact points (10-11) of the pressure switch “PS4-1” are still closed, because the pressure drop didn't decrease lower than the set value (0,45 bar), the timer starts the backflushing cycle again.

For safety reasons, the pressure switch contact points “PS4-2” (12-13) are set at 0,75 bar. Triggering this contact points starts a backflushing cycle and through the relay “K4-2” a signal is given to the corresponding light “L4-3”.

With the adjustable timer “KT4-1” it is possible to set a time interval between each backflushing cycle independent from the pressure switch, so that the filter can start a new cycle. The time interval begins again after each backflushing cycle, even if it was started by the timer, the pressure switch or manually.

The test key “P4-2” starts a new backflushing cycle.

**3.1 Connection Diagram**

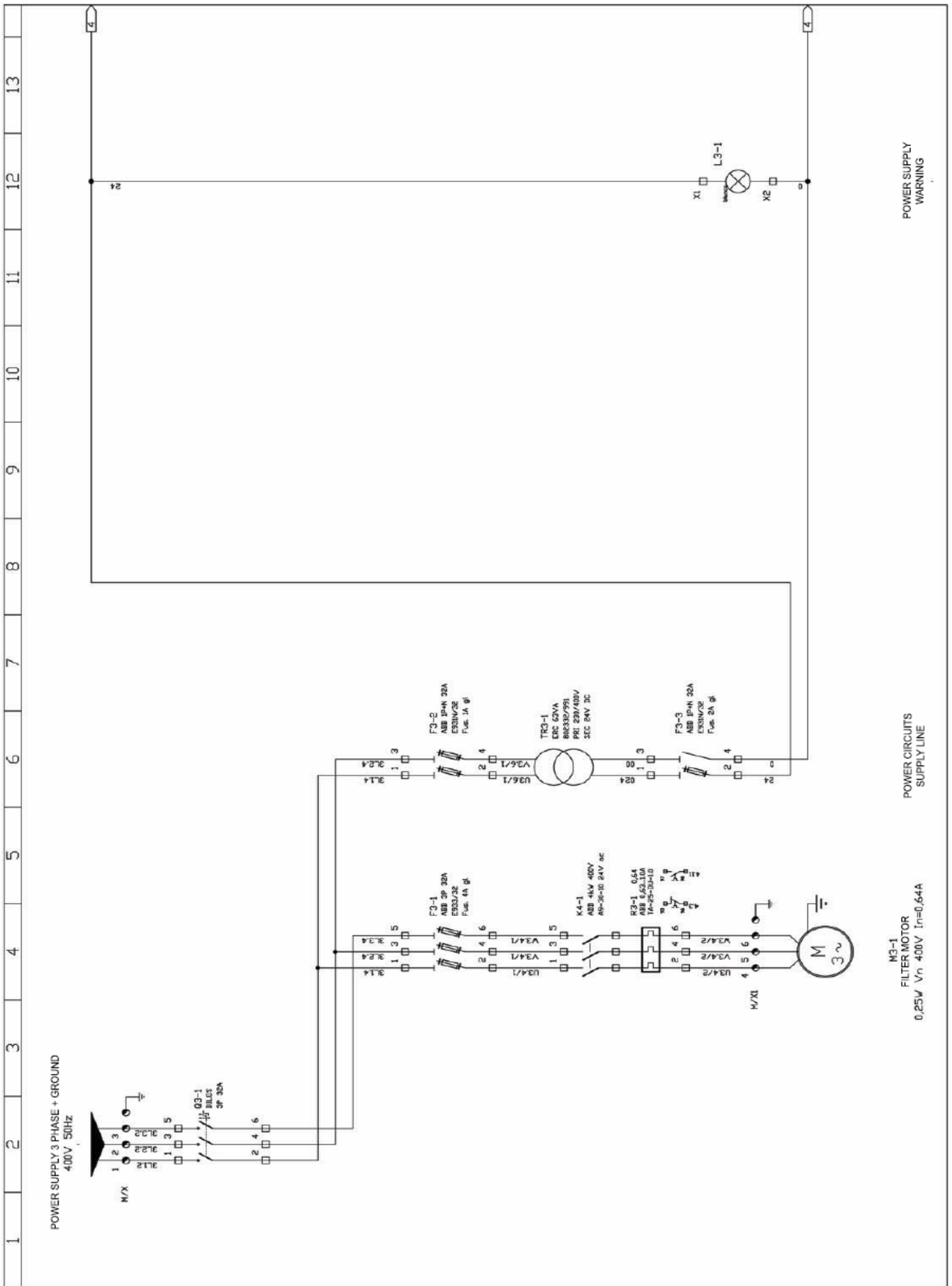

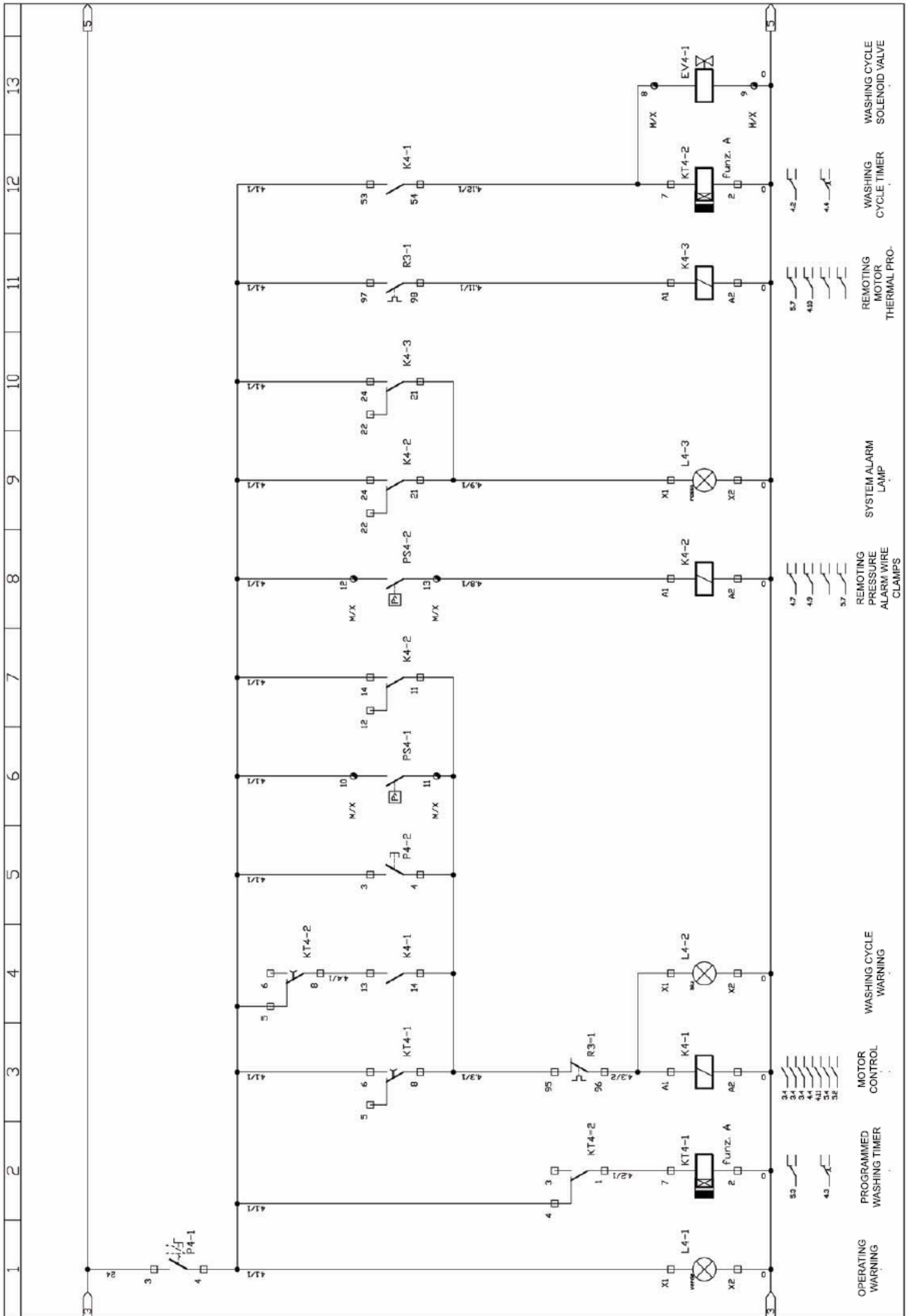



### 3.2 Remote Control

The electrical terminal box is equipped with some points for remote control. Following signals are available:

- System fault
- Backflushing cycle
- Electrical motor safety
- High level pressure drop alarm

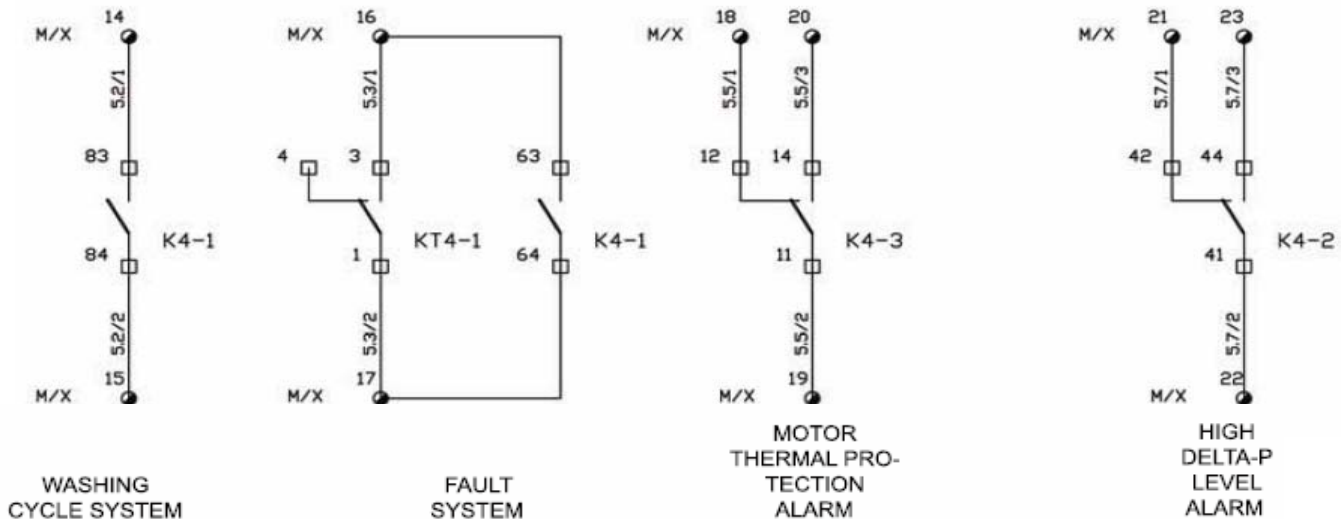

### 4. Maintenance

Maintenance of backflushing filters is generally simple and safe. However a difference in the type of filtered liquid should be noted. Usually the filtered fluids are either water, saltwater or viscous liquids. If it is saltwater, corrosion problems have to be considered. Even with short holding times experienced the filter should be drained and cleaned extensively with fresh clean water.

Generally it is recommended:

#### EVERY 6 MONTHS

- Check the settings of the installed instruments.

#### EVERY 12 MONTHS

- Besides the above mentioned, check and if necessary replace the internal and external gaskets and seals.
- Check the lubricant level on the reduction drive, add/change if necessary.
- Check if the drain valve functions correctly.

#### EVERY 24 MONTHS

- Perform the same checks/maintenance as for 6 and 12 months intervals.
- Disassemble all the internal parts of the filter, inspect carefully, especially the welds, and clean the housing.
- Replace all the internal/external gaskets and seals and any other wear parts.
- The condition of the filter elements and retaining/sealing areas should be inspected.
- Check the condition of the internal sealing devices and sliding shoe; replace if necessary.

## **5. Change of inner parts and elements**

### **Disassembly**

The changing of the inner parts is necessary at least every 4 years, with normal operating use, or less depending on the frequency of operations.

This has to be carried out as follows:

- Turn off the power supply
- Connect the air-bleed "C" and the drain plug "F" with suitable pipes and place a collecting pan for the operating fluid flowing out
- Open the air-bleed "C" and drain plugs "F" until no more operating fluid flows out
- Unscrew the 4 nuts M10 and remove the geared motor (1) from the cover flange (6)
- Remove the spline 8x10 from the shaft (2)
- Remove the coupling flange (3)
- Release the screws (4) of the lid and remove the filter lid (6) and his gasket (5)
- Release the screws (7) of the retaining plate (8) of the filter elements
- Remove the retaining plate (8) of the filter elements. Pay attention to do it carefully in order to avoid damaging the elements (9)
- Check the wearing status of the shoe (11) and the gasket (7) (15) (16) and replace those parts which are out of order. Depending on the filter size, the shoes (11) could be 1 or 2 placed each one on its rotating arm.
- Check the element status and replace them if necessary releasing the nuts (13) and the cover (14)

**Clean the inside of the filter housing. Pay attention that no contaminated and no dirt fluid get into the clean side.**

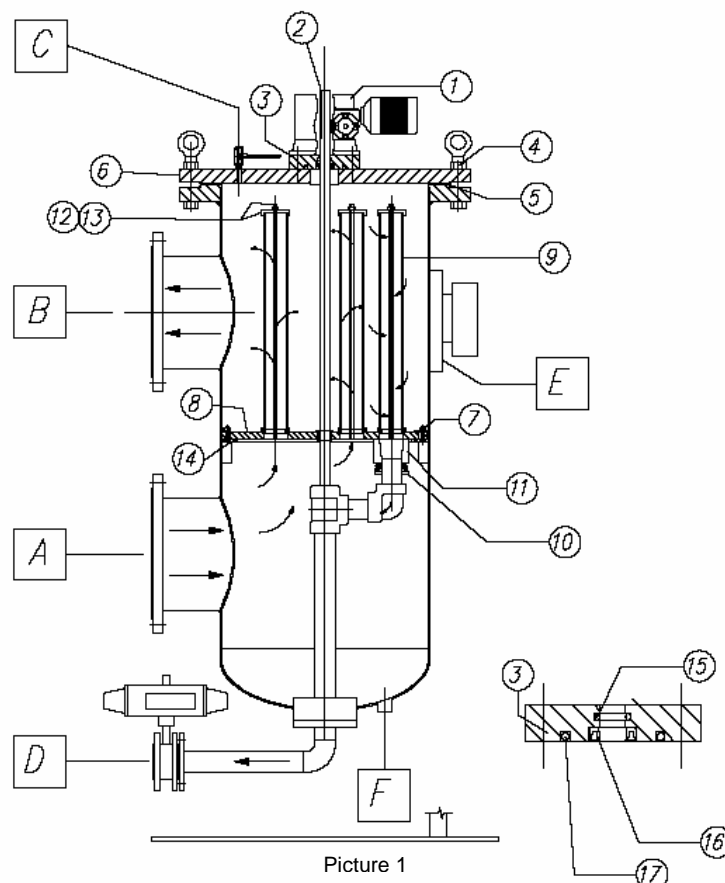

## **6. Assembly**









After the service operation:

- Assemble the element retaining plate paying attention to do it very carefully
- Centre the retaining plate (8) with the rotating shaft (2) and fix the bolts (7)
- Fix the filter lid (6) onto the filter housing and tighten the screw plugs (4) slightly with the hex head screw, turning moment 200 N.
- Insert the coupling flange (3) and the spline 8x10 on the shaft (2)
- Put the geared motor (1) on the shaft and tighten the 4 nuts M10
- Turn on the power supply and press the test key "P4-2"
- While the geared motor is turning (1), the screws (4) of the lid (6) have to be tightened over cross.
- Turn off the power supply and tighten again the screws (4) over cross with a turning moment of 2100 N
- Now the serviced filter is operational again.

In general take care about the absolute cleanness during the service operation. No dirt respectively no impurities should penetrate the filter. New elements and commissioning parts should be taken out of the packing shortly before they are replaced in the filter housing in order to avoid mechanical damage. While opening the filter control the seals and their quality. Damaged seals have to be replaced by new ones.

**7. Annex**

**Wire clamp list**

WIRE CLAMP SOCKET NR.	WIRE CLAMP NR.	WIRE CLAMP SECTION (mm <sup>2</sup> )	ENTRY WIRE NUM-BERING	MULTIPLE CABLE TAG	EXIT WIRE NUM-BERING	DUTY	DUTY DESCRIPTION
M/B-01		10					PROTECTION CONDUCTOR
	1	4			3L1.2	R	GENERAL POWER SUPPLY LINE 3 PH 50HZ 400V
	2	4			3L2.2	S	GENERAL POWER SUPPLY LINE 3 PH 50HZ 400V
	3	4			3L3.2	T	GENERAL POWER SUPPLY LINE 3 PH 50HZ 400V
		4					PROTECTION CONDUCTOR
	4	4	U-3.4/2		U-3.4/2	U	MOTOR SUPPLY "M3-1"
	5	4	V-3.4/2		V-3.4/2	V	MOTOR SUPPLY "M3-1"
	6	4	W-3.4/2		W-3.4/2	W	MOTOR SUPPLY "M3-1"
		8					PROTECTION CONDUCTOR
	8	4	4.12/1		4.12/1	COM.	WASHING CYCLE 24Vac SOLENOID VALVE
	9	4	0		0	N.D.	WASHING CYCLE 24Vac SOLENOID VALVE
	10	4	4.1/1		4.1/1	COM.	WASHING CONTROL DIFFERENTIAL PRESSURE SWITCH (OPERATING)
	11	4	4.3/1		4.3/1	N.D.	WASHING CONTROL DIFFERENTIAL PRESSURE SWITCH (OPERATING)
	12	4	4.1/1		4.1/1	COM.	ALARM DIFFERENTIAL PRESSURE SWITCH
	13	4	4.8/1		4.8/1	N.D.	ALARM DIFFERENTIAL PRESSURE SWITCH
	14	4	5.2/1		5.2/1	N.O.	SPDT REMOTING POINT WASHING CYCLE
	15	4	5.2/2		5.2/2	COM.	SPDT REMOTING POINT WASHING CYCLE
	16	4	5.3/1		5.3/1	N.O.	SPDT REMOTING POINT FAULT SYSTEM
	17	4	5.3/2		5.3/2	COM.	SPDT REMOTING POINT FAULT SYSTEM
	18	4	5.5/1		5.5/1	N.C.	SPDT REMOTING POINT MOTOR THERMAL PROTECTION
	19	4	5.5/2		5.5/2	COM.	SPDT REMOTING POINT MOTOR THERMAL PROTECTION
	20	4	5.5/3		5.5/3	N.D.	SPDT REMOTING POINT MOTOR THERMAL PROTECTION
	21	4	5.7/1		5.7/1	N.C.	SPDT REMOTING POINT HIGH DELTA-P LEVEL ALARM
22	4	5.7/2		5.7/2	COM.	SPDT REMOTING POINT HIGH DELTA-P LEVEL ALARM	
23	4	5.7/3		5.7/3	N.D.	SPDT REMOTING POINT HIGH DELTA-P LEVEL ALARM	
	10					PROTECTION CONDUCTOR	