

Vickers®

# Vane Pumps

---



## Single and Double Vane Pumps

Model Series V10, V20, V2010, and V2020  
for Industrial Equipment



**VICKERS**

Revised 1/95

# Introduction

---

Series V10, V20, V2010, and V2020 fixed displacement pumps are of Vickers “balanced vane type” construction. V10 and V20 single pumps have rated flow capacities of 1 to 7 USgpm and 6 to 13 USgpm, respectively.

Double pumps provide a single power source capable of serving two separate hydraulic circuits, or of providing greater volume through the combined delivery of both sections. In either type of application, two pumps in a single

housing result in a more compact, simple installation and can be driven through a single shaft coupling.

V2010 double pumps have capacities of 6 to 13 USgpm and 1 to 7 USgpm for their shaft-end and cover-end pumps, respectively. V2020 double pumps have capacities of 6 to 13 USgpm and 6 to 11 USgpm for their shaft-end and cover-end pumps, respectively.

All models are designed for use with oil or synthetic fire-resistant fluids.

Shaft rotation is either clockwise or counterclockwise, but can be changed by changing the assembly of internal parts.

SAE 2-bolt mounting flanges are standard, and foot-mounting brackets are optional. Many electric motor manufacturers can supply drip-proof or totally enclosed, fan cooled motors with end bells on which the pumps can be mounted.

## Features and Benefits

---

### Enhanced Bearing Life

Internal inlet and outlet pressure chambers are diametrically opposed. As a result, pressure-induced radial loads are balanced, and bearings have to carry the external load only.

### High Performance

Low vane tip/ring loading allows high pressure operation. High speeds are possible because the inlet flow paths are designed to give uniform oil acceleration, and thus better filling characteristics, particularly at low inlet pressures.

### Extended Product Life

The superior design of these pumps makes them last longer. They’ve proven they’ll hold up in rugged applications.

### Low Cost

Vickers’ efficient design produces extra horsepower per dollar of pump investment, providing industry with low pump cost per horsepower capacity.

### Versatility

High flow, pressure and speed capabilities enable these pumps to meet the hydraulic circuit needs of many types of modern machinery.

# Table of Contents

---

## Basic Performance Data – Single and Double Pumps

Operating Characteristics at 1200 r/min with Petroleum Oil ..... 4

Maximum Speeds and Pressures Using Fire-resistant Fluids ..... 4

Speed Rating per Inlet Condition ..... 4

## Single Pumps – V10 and V20 Series

Model Codes ..... 5

Specifications ..... 5

Performance Curves ..... 6

Dimensions ..... 11

## Double Pumps – V2010 and V2020 Series

Model Codes ..... 13

Specifications ..... 14

Performance Curves ..... 15

Dimensions ..... 19

**Foot Bracket Kits** ..... 21

**Application and Service Information** ..... 22

# Basic Performance Data – Single and Double Pumps

## Typical operating characteristics at 1200 r/min with petroleum oil

Ring size		Data based on performance at oil temperature of 49° C (120° F), viscosity 32 cSt at 38° C (150 SUS at 100° F)							
		7 bar (100 psi)		69 bar (1000 psi)		138 bar (2000 psi)		155 bar (2250 psi)	
V10 single pump †	V20 single pump ‡	Lpm (USgpm)	Input kW (hp)	Lpm (USgpm)	Input kW (hp)	Lpm (USgpm)	Input kW (hp)	Lpm (USgpm)	Input kW (hp)
1	–	3,8 (1)	0,2 (.3)	2,7 (.7)	0,5 (.8)	2,5 (.65)	1 (1.4)	2,3 (.6)	1,2 (1.6)
2	–	7,6 (2)	0,2 (.3)	6,8 (1.8)	1,3 (1.75)	6,4 (1.7)	2,2 (3)	6 (1.6)	2,8 (3.8)
3	–	11,4 (3)	0,3 (.4)	10,6 (2.8)	1,6 (2.2)	10,2 (2.7)	3,3 (4.4)	9,8 (2.6)	3,7 (5)
4	–	15,1 (4)	0,3 (.4)	14 (3.7)	2,2 (3)	13,6 (3.6)	4,3 (5.8)	13,2 (3.5)	4,8 (6.5)
5	–	18,9 (5)	0,4 (.6)	18,2 (4.8)	2,7 (3.6)	17,4 (4.6)	5,2 (7)	17 (4.5)	5,8 (7.8)
6	–	23,1 (6.1)	0,7 (.9)	21,6 (5.7)	3,7 (5)	20,4 (5.4)	6,7 (9)	20,1 (5.3)	7,5 (10)
7	–	27,2 (7.2)	0,7 (1)	25,7 (6.8)	4,1 (5.5)	24,6 (6.5)	7,8 (10.4)	23,8 (6.3)	8,7 (11.6)
–	6	23,5 (6.2)	0,9 (1.25)	20,1 (5.3)	3,6 (4.9)	19,7 (5.2)	6,3 (8.4)	19,3 (5.1)	7,5 (10)
–	7	26,9 (7.1)	0,9 (1.25)	25 (6.6)	3,7 (5)	23,5 (6.2)	6,9 (9.2)	23,1 (6.1)	8,6 (11.5)
–	8	31 (8.2)	0,9 (1.25)	28,8 (7.6)	4,2 (5.6)	27,2 (7.2)	8,1 (10.9)	26,9 (7.1)	10,4 (14)
–	9	34,8 (9.2)	1 (1.3)	32,6 (8.6)	4,6 (6.2)	31 (8.2)	9 (12.1)	30,7 (8.1)	11,9 (16)
–	11	43,5 (11.5)	1 (1.3)	37,8 (11)	5,7 (7.6)	39,7 (10.5)	10,9 (14.6)	39,4 (10.4)	13 (17.5)
–	12	45,4 (12)	1 (1.3)	43,2 (11.4)	6,1 (8.2)	40,9 (10.8)	11,6 (15.6)	–	–
–	13	51,1(13.5)	1 (1.3)	49,2 (13)	6,6 (8.8)	47,3 (12.5)	12,4 (16.7)	–	–

† Also cover-end ring of V2010 double pump .

‡ Also *shaft-end* ring of V2010 and V2020 double pumps, and *cover-end* ring (except sizes 12 & 13) of V2020 double pump.

NOTE: See curves for complete operating characteristics with petroleum oil. See page 6 for single pumps. See page 15 for double pumps.

## Maximum speeds & pressures using fire-resistant fluids

Ring size	Maximum speed by fluid type – r/min		Maximum pressure by fluid type – bar (psi)		
	Water-glycol and water-in-oil emulsion	Synthetic fluid	Water glycol	Water-in-oil emulsion	Synthetic fluid
1, 2, 3, 4, 5	1800	1800	124 (1800)	103 (1500)	138 (2000)
6, 7, 8, 9	1800	1800	124 (1800)	109 (1575)	138 (2000)
11	1800	1500	109 (1575)	93 (1350)	138 (2000)
12,13	1800	1500	109 (1575)	93 (1350)	124 (1800)

NOTE: 3 inches of Hg is the maximum inlet vacuum for the maximum speeds above. See page 22 for complete application details.

## Speed rating per inlet condition

Maximum operating speeds shown on performance curves are for pumps operating at 0 psi inlet condition. To compute maximum operating speeds at other inlet conditions, use appropriate speed rating correction factor shown on the curve on the right.

Example:

Max. speed @ 0 psi inlet      2800 rpm

Correction factor @ 5 in. Hg    x .93

Max. speed @ 5 in. Hg inlet    2604 rpm

Pump inlet suction should not exceed 5 in. Hg vacuum for petroleum oil or 3 in. Hg vacuum for other fluid types. Positive pressure on inlet should not exceed 10 psi.

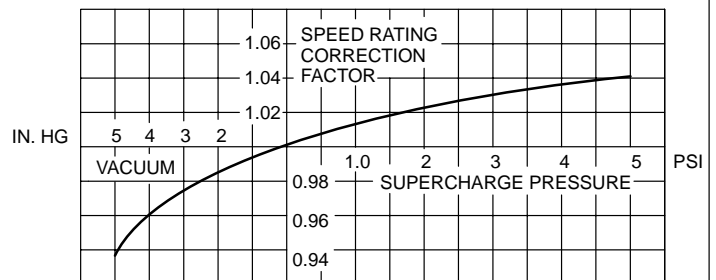

# Single Pumps

## Model Codes

**F3 - V 10 - 1 P 5 S - 1 C 20 L**

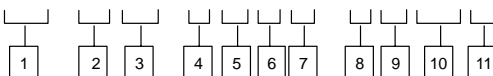

### 1 Special Seals

Omit if not required.

See page 23 for information on seals.

### 2 Vane pump

### 3 Series

10 or 20

### 4 Mounting

1 – 2-bolt flange, 3.25" pilot (standard)  
6 – 2-bolt flange, 4.00" pilot (optional)

See page 21 for optional foot bracket kits.

### 5 Inlet port connections

P – 1" NPT thread (V10 only)  
1 1/4" NPT thread (V20 only)  
S – 1.3125-12 straight thread (V10 only)  
1.625-12 straight thread (V20 only)

### 6 Ring size

(Delivery at 1200 r/min and 100 psi)

1 – 1 USgpm  
2 – 2 USgpm  
3 – 3 USgpm  
4 – 4 USgpm  
5 – 5 USgpm  
6 – 6 USgpm  
7 – 7 USgpm

V10 series

6 – 6 USgpm  
7 – 7 USgpm  
8 – 8 USgpm  
9 – 9 USgpm  
11 – 11 USgpm  
12 – 12 USgpm  
13 – 13 USgpm

V20 series

### 7 Outlet port connections

P – 1/2" NPT thd. (V10 only)  
R – 1.1875–12 St. thd. (V20 only)  
S – .750–16 St. thd. (V10 only)  
1.0625–12 St. thd. (V20 only)

### 8 Shafts

1 – Straight keyed  
11 – Splined  
38 – 11 Tooth – 3/4" OD.  
62 – Splined (V20 only)

### 9 Position of outlet port

(Viewed from cover end of pump)  
A – Opposite inlet port  
B – 90° CCW from inlet  
C – In line with inlet  
D – 90° CW from inlet

### 10 Design

11 – V20 series  
20 – V10 series  
Subject to change.

### 11 Shaft rotation

(Viewed from shaft end of pump)  
L – Left hand (counterclockwise).  
Omit for right hand.

## Specifications

Based on using petroleum oil at 49° C (120° F), viscosity 32 cSt at 38° C (150 SUS at 100° F), and 0 psi inlet pressure

Model series	Ring size (Delivery USgpm @ 1200 r/min & 100 psi)	Displ. cm <sup>3</sup> /r (in <sup>3</sup> /r)	Max. speed r/min	Maximum pressure bar (psi)	Typical delivery L/min (USgpm) @ max. speed & pressure	Typical input power kW (hp) @ max. speed & pressure	Weight kg (lb)
V10	1	3,3 (.20)	4800	172 (2500)	13,6 (3.6)	5,2 (7)	4,5 - 6,8 (10 - 15)
	2	6,6 (.40)	4500	172 (2500)	27,6 (7.3)	10,1 (13.6)	
	3	9,8 (.60)	4000	172 (2500)	35,6 (9.4)	13,3 (17.8)	
	4	13,1 (.80)	3400	172 (2500)	41,3 (10.9)	15,2 (20.4)	
	5	16,4 (1.00)	3200	172 (2500)	48,5 (12.8)	17 (22.8)	
	6	19,5 (1.19)	3000	152 (2200)	55,3 (14.6)	18,3 (24.5)	
	7	22,8 (1.39)	2800	138 (2000)	60,6 (16)	17,9 (24)	
V20	6	19,5 (1.19)	3400	172 (2500)	60,9 (16.1)	21,6 (29)	7,3 - 8,2 (16 - 18)
	7	22,8 (1.39)	3000	172 (2500)	63,2 (16.7)	22 (29.5)	
	8	26,5 (1.62)	2800	172 (2500)	67 (17.7)	24,2 (32.5)	
	9	29,7 (1.81)	2800	172 (2500)	75 (19.8)	26,5 (35.5)	
	11	36,4 (2.22)	2500	172 (2500)	86,7 (22.9)	28 (37.5)	
	12	39 (2.38)	2400	152 (2200)	87,1 (23)	26,8 (36)	
	13	42,4 (2.59)	2400	152 (2200)	98 (25.9)	29,1 (39)	

See page 4 for speed correction curve.

# Single Pumps

## V10 Performance

Oil temp. 49°C (120°F), viscosity  
 32 cSt (150 SUS) @ 38°C (100°F),  
 inlet pressure zero

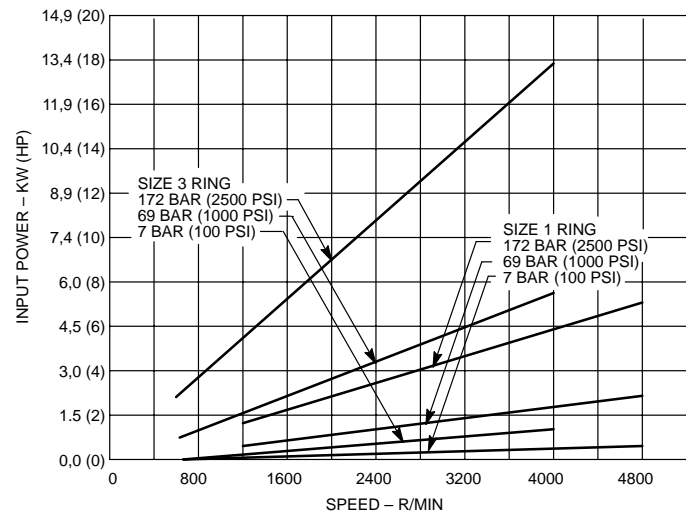
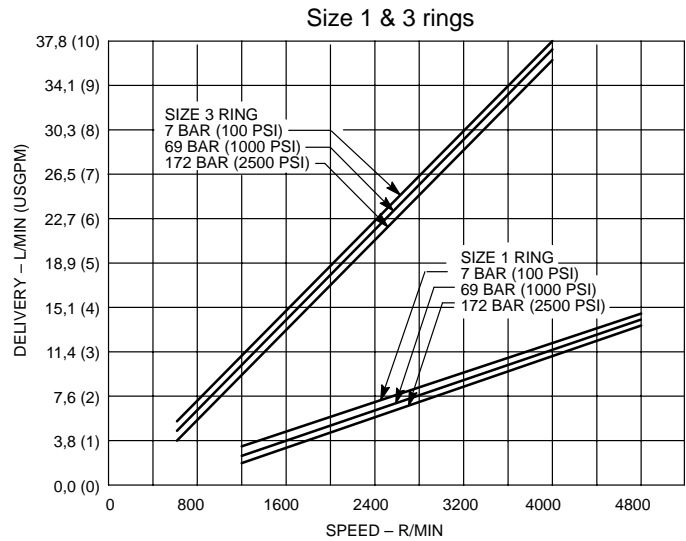

# Single Pumps

## V10 Performance

Oil temp. 49°C (120°F), viscosity  
32 cSt (150 SUS) @ 38°C (100°F),  
inlet pressure zero

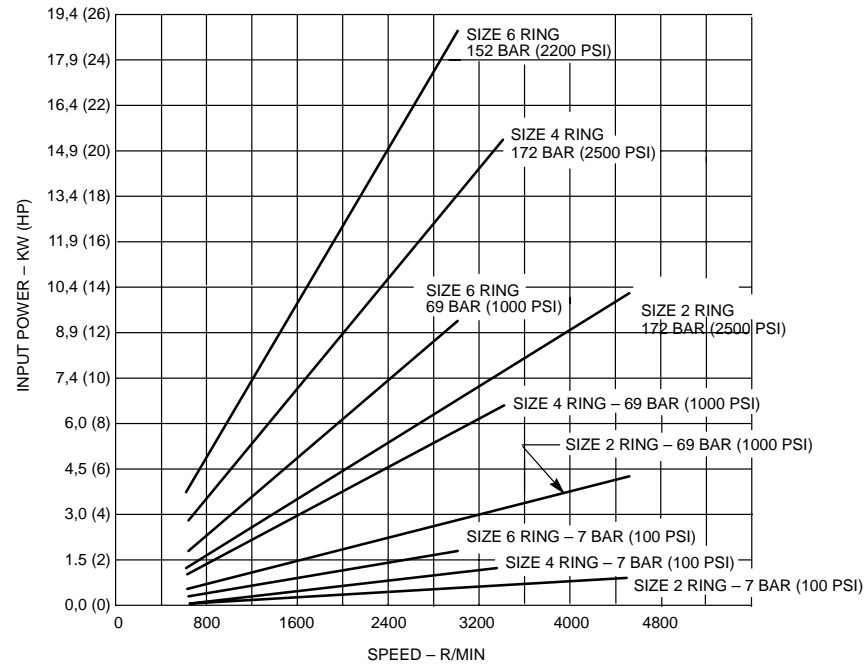
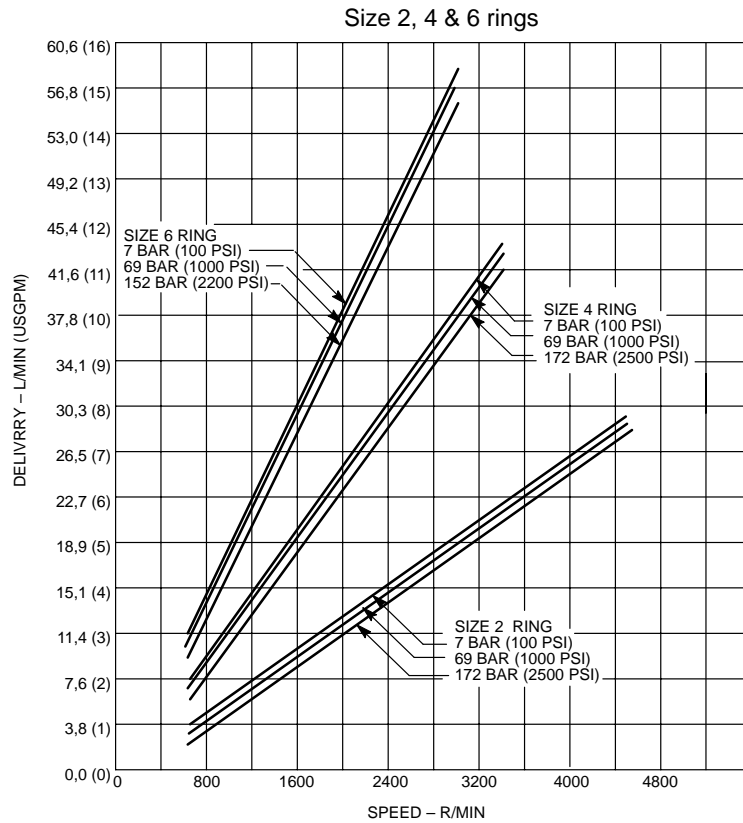

# Single Pumps

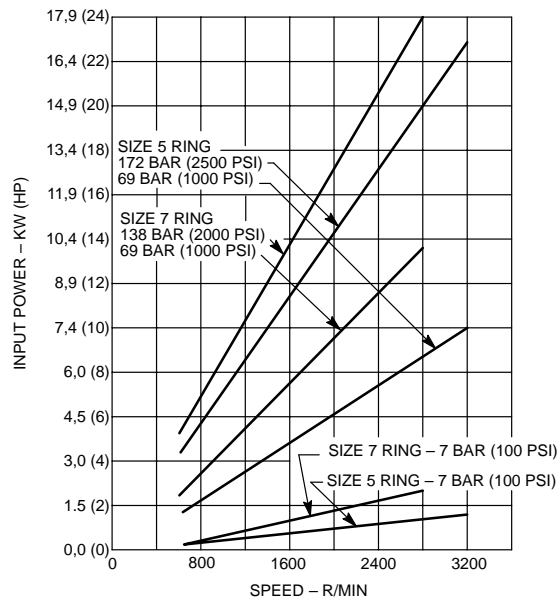
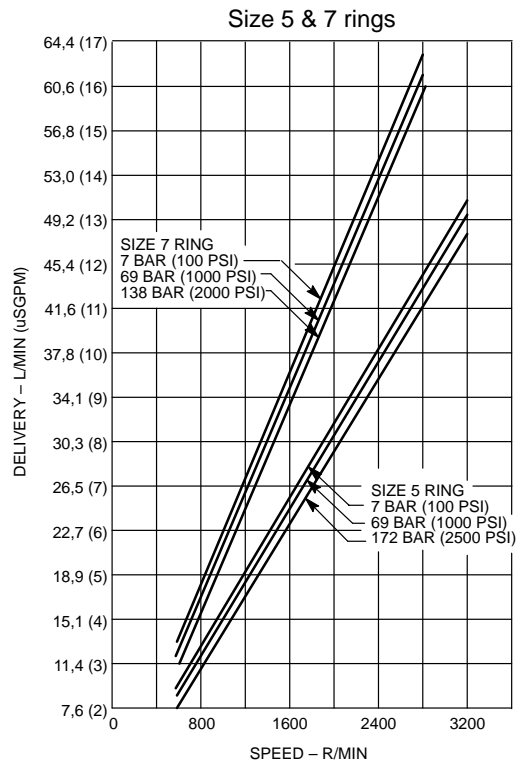



# Single Pumps

## V20 Performance

Oil temp. 49°C (120°F), viscosity  
32 cSt (150 SUS) @ 38°C (100°F),  
inlet pressure zero

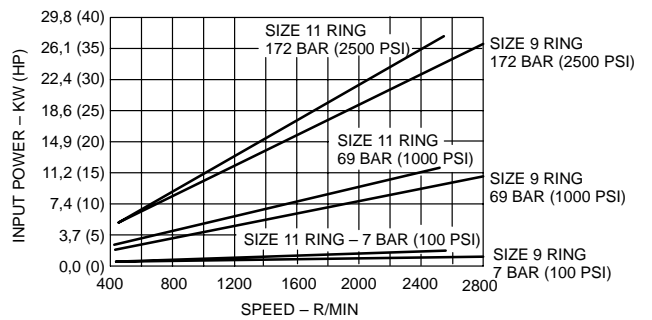
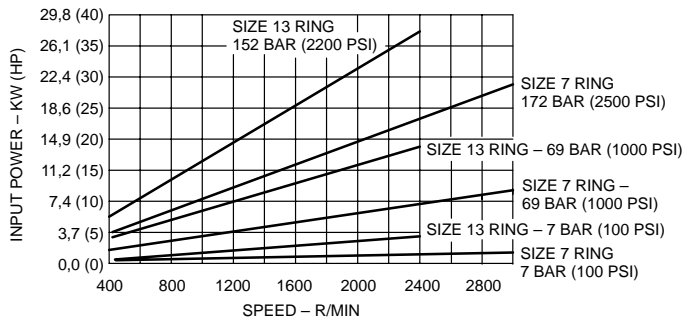
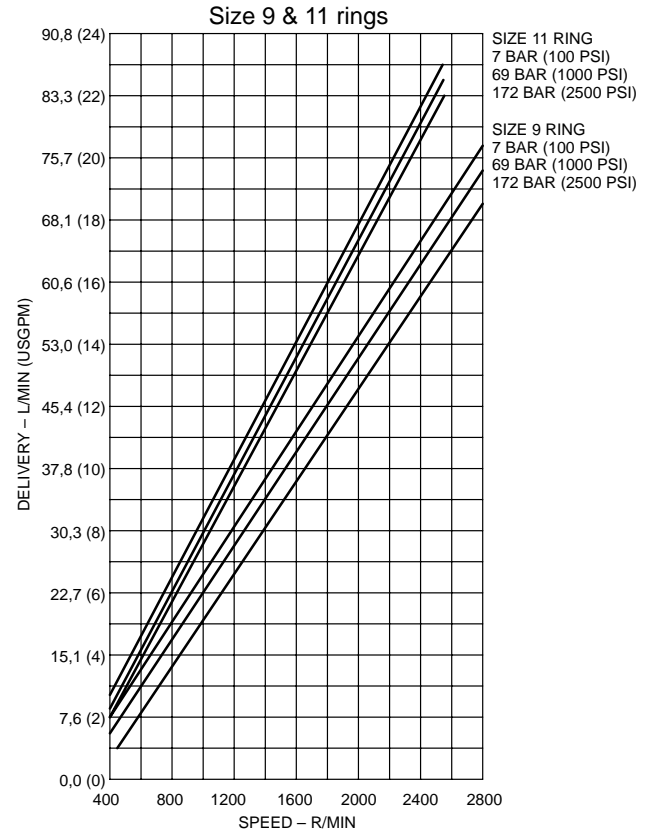
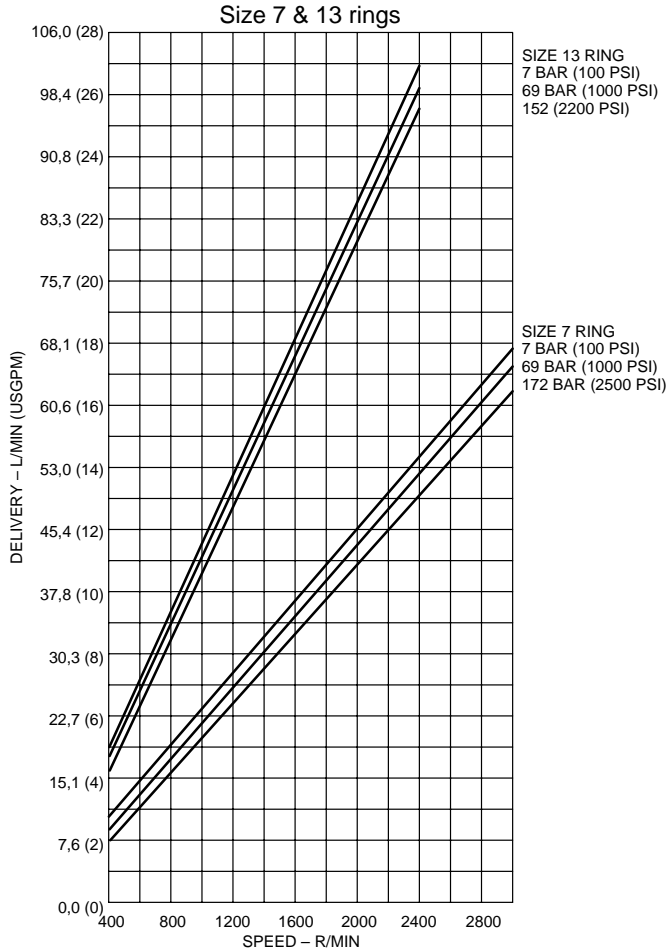

# Single Pumps

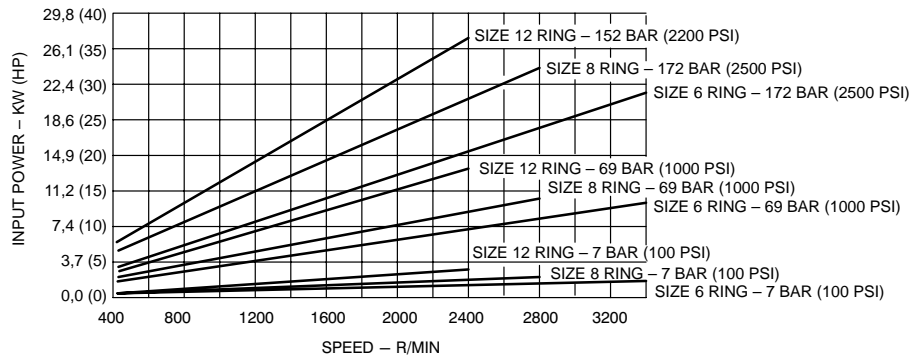
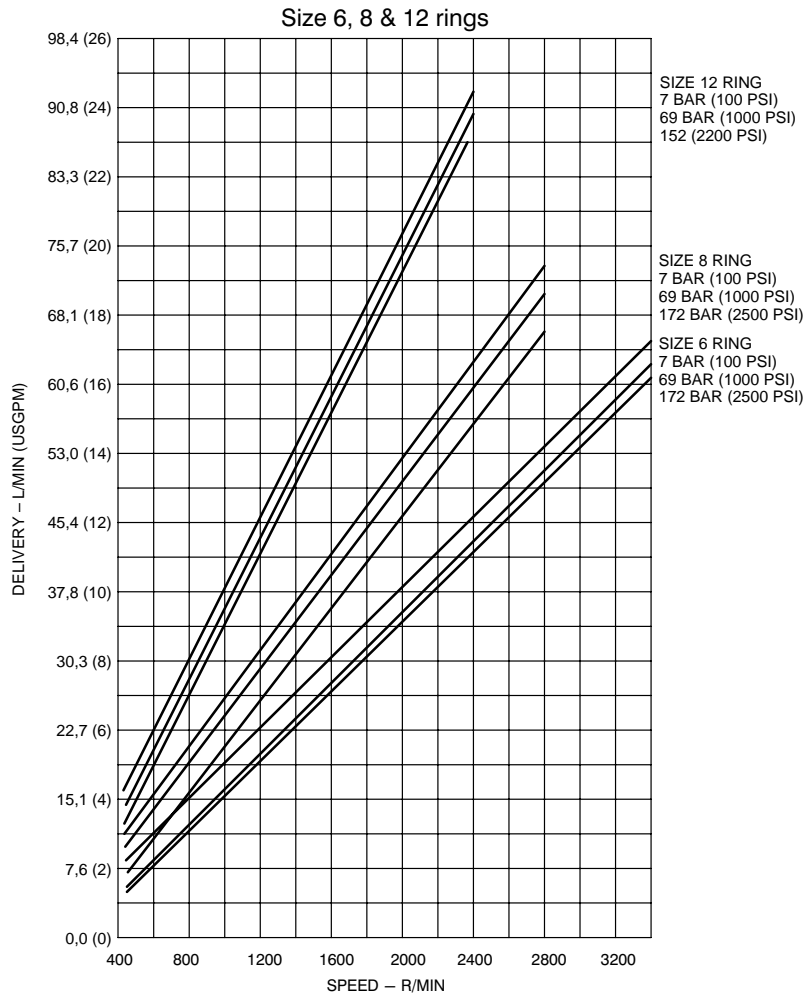

# Single Pumps

## V10 Dimensions

### Millimeters (inches)

See page 21 for foot mounting dimensions.

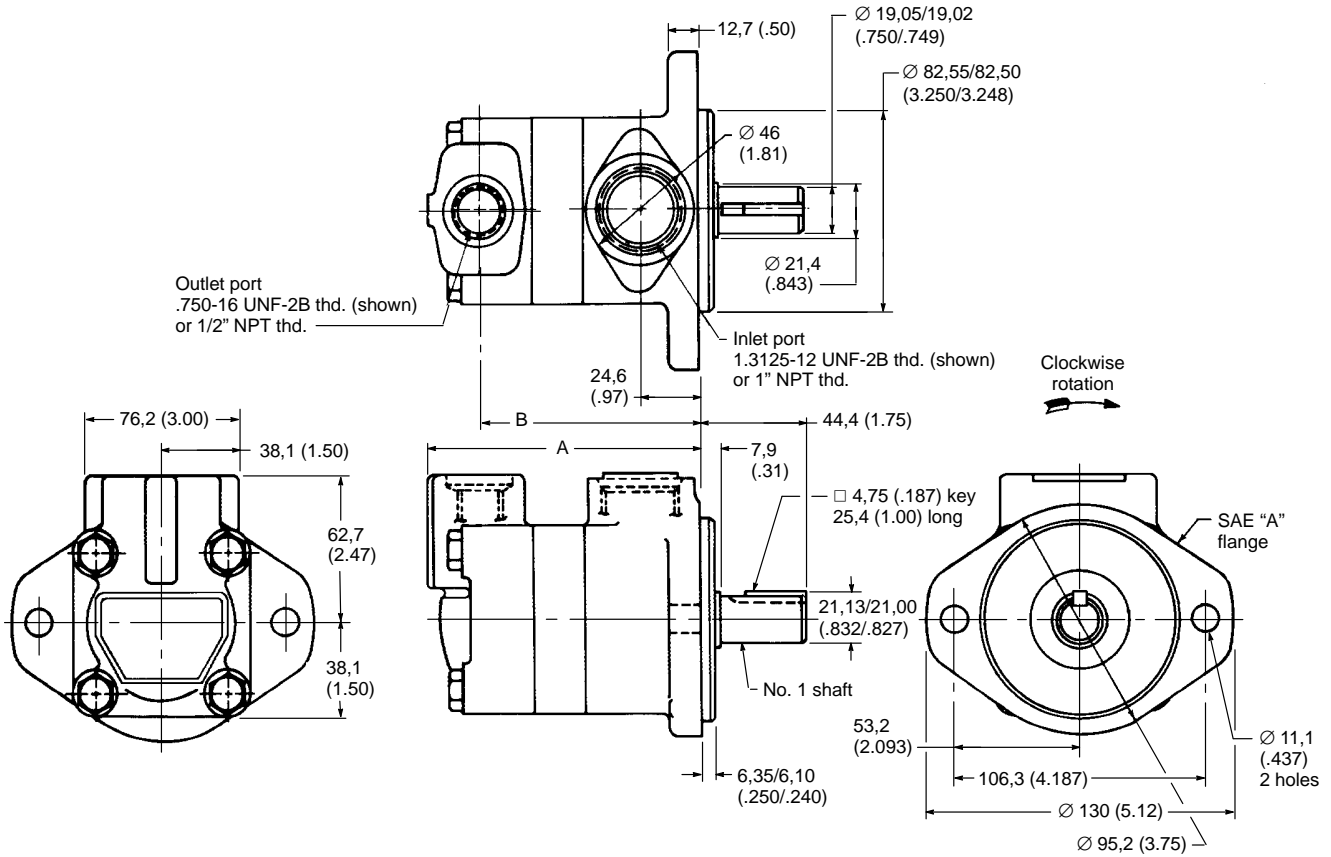

Number 11 shaft

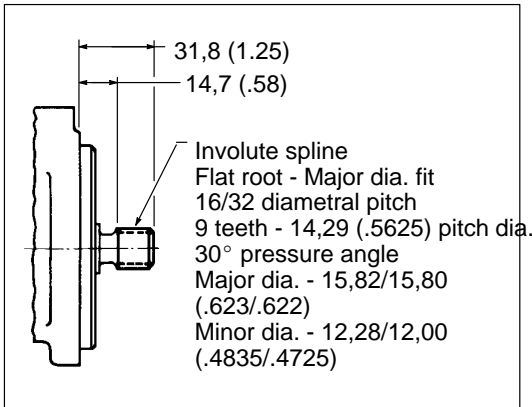

Ring size	Dimension	
	A	B
1	115,6 (4.55)	91,9 (3.62)
2	115,6 (4.55)	91,9 (3.62)
3	115,6 (4.55)	91,9 (3.62)
4	121,9 (4.80)	98,3 (3.87)
5	121,9 (4.80)	98,3 (3.87)
6	127,0 (5.00)	103,4 (4.07)
7	127,0 (5.00)	103,4 (4.07)

# Single Pumps

## V20 Dimensions

Millimeters (inches)

See page 21 for foot mounting dimensions.

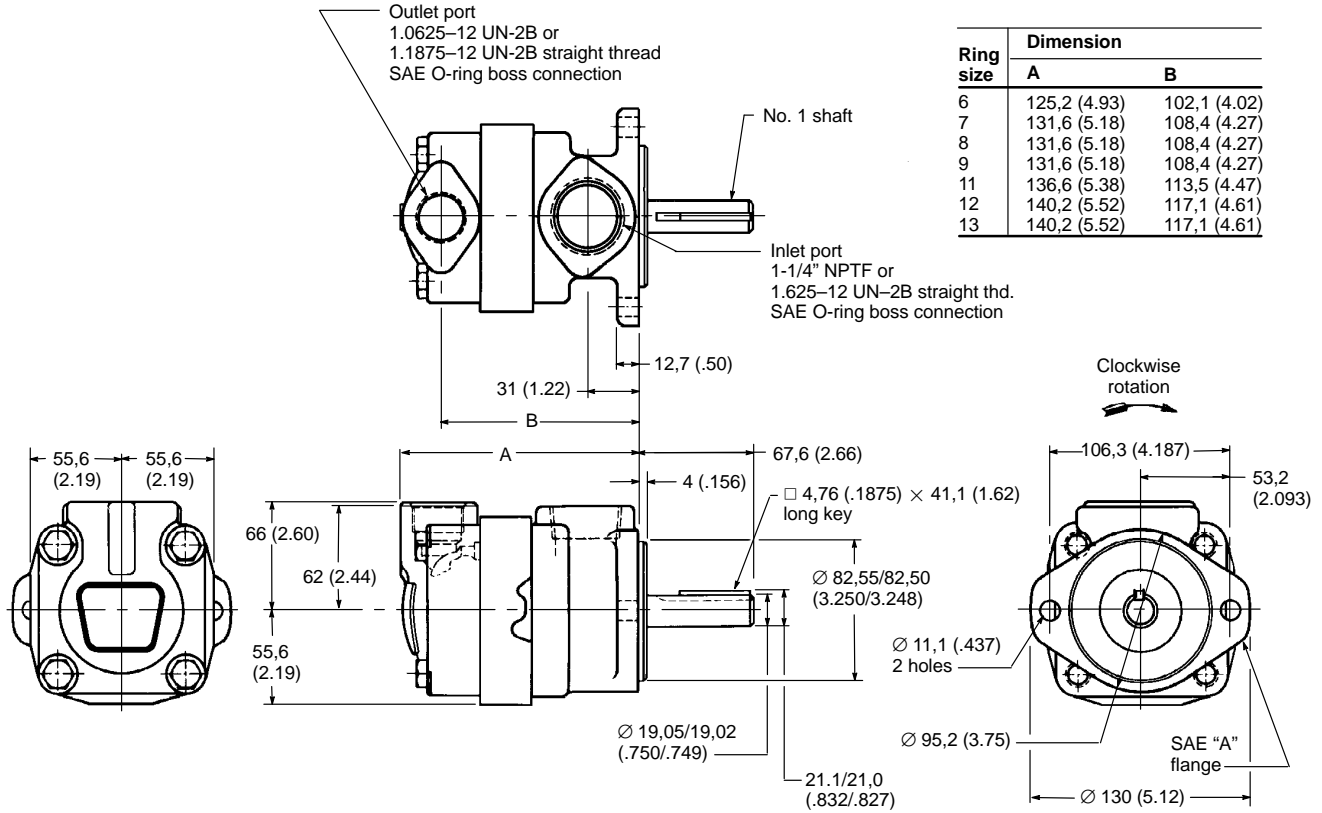

Ring size	Dimension	
	A	B
6	125,2 (4.93)	102,1 (4.02)
7	131,6 (5.18)	108,4 (4.27)
8	131,6 (5.18)	108,4 (4.27)
9	131,6 (5.18)	108,4 (4.27)
11	136,6 (5.38)	113,5 (4.47)
12	140,2 (5.52)	117,1 (4.61)
13	140,2 (5.52)	117,1 (4.61)

Number 11 shaft

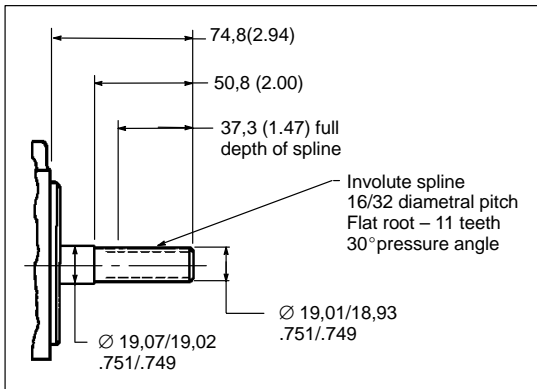

Number 62 shaft

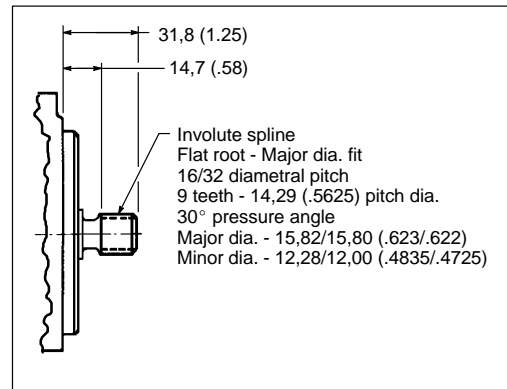

# Double Pumps

## Model Codes

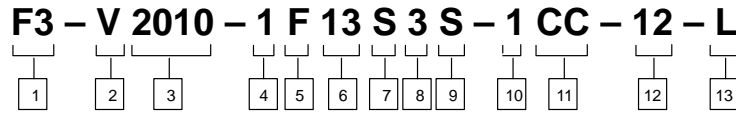

**1 Special Seals**  
Omit if not required.  
See page 23 for information on seals.

**2 Vane pump**

**3 Series**  
2010 or 2020

**4 Mounting**  
1 – 2-bolt flange, 4.00" pilot (standard)  
6 – 2-bolt flange, 3.25" pilot (optional)  
See page 21 for optional foot bracket kits.

**5 Inlet port connections**  
F – 4-bolt flange 1.50 dia. (V2010)  
2.00 dia. (V2020)

**6 Shaft-end pump ring size**  
(delivery at 1200 rpm & 100 psi)  
6 - 6 USgpm      11 - 11 USgpm  
7 - 7 USgpm      12 - 12 USgpm  
8 - 8 USgpm      13 - 13 USgpm  
9 - 9 USgpm

**7 No. 1 outlet port (shaft end)**  
S – 1.062-12 UN-2B thd.

**8 Cover-end pump ring size**  
(delivery at 1200 r/inm and 100 psi)  
1 – 1 USgpm  
2 – 2 USgpm  
3 – 3 USgpm  
4 – 4 USgpm  
5 – 5 USgpm  
6 – 6 USgpm  
7 – 7 USgpm  
6 – 6 USgpm  
7 – 7 USgpm  
8 – 8 USgpm  
9 – 9 USgpm  
11 – 11 USgpm

V2010  
V2020

**9 No. 2 outlet port (cover end)**  
S – .750-16 St. Thd. (V2010)  
1.062–12 St. Thd. (V2020)

**10 Shafts**  
1 – Straight keyed  
11 – Splined

**11 Position of outlet**  
(Viewed from cover end of pump)  
**V2010**  
*With no. 1 outlet opposite inlet*  
AA – No. 2 outlet 135° CCW from inlet  
AB – No. 2 outlet 45° CCW from inlet  
AC – No. 2 outlet 45° CW from inlet  
AD – No. 2 outlet 135° CW from inlet  
  
*With no. 1 outlet 90° CCW from inlet*  
BA – No. 2 outlet 135° CCW from inlet  
BB – No. 2 outlet 45° CCW from inlet  
BC – No. 2 outlet 45° CW from inlet  
BD – No. 2 outlet 135° CW from inlet  
  
*With no. 1 outlet in line with inlet*  
CA – No. 2 outlet 135° CCW from inlet  
CB – No. 2 outlet 45° CCW from inlet  
CC – No. 2 outlet 45° CW from inlet  
CD – No. 2 outlet 135° CW from inlet  
  
*With no. 1 outlet 90° CW from inlet*  
DA – No. 2 outlet 135° CCW from inlet  
DB – No. 2 outlet 45° CCW from inlet  
DC – No. 2 outlet 45° CW from inlet  
DD – No. 2 outlet 135° CW from inlet

**V2020**  
*With no. 1 outlet opposite inlet*  
AA – No. 2 outlet opposite inlet  
AB – No. 2 outlet 90° CCW from inlet  
AC – No. 2 outlet in line with inlet  
AD – No. 2 outlet 90° CW from inlet  
  
*With no. 1 outlet 90° CCW from inlet*  
BA – No. 2 outlet opposite inlet  
BB – No. 2 outlet 90° CCW from inlet  
BC – No. 2 outlet in line with inlet  
BD – No. 2 outlet 90° CW from inlet  
  
*With no. 1 outlet inline with inlet*  
CA – No. 2 outlet opposite inlet  
CB – No. 2 outlet 90° CCW from inlet  
CC – No. 2 outlet in line with inlet  
CD – No. 2 outlet 90° CW from inlet  
  
*With no. 1 outlet 90° CW from inlet*  
DA – No. 2 outlet opposite inlet  
DB – No. 2 outlet 90° CCW from inlet  
DC – No. 2 outlet in line with inlet  
DD – No. 2 outlet 90° CW from inlet

**12 Design**  
12 – V2010 series  
30 – V2020 series  
Subject to change.

**13 Shaft rotation**  
(Viewed from shaft end of pump)  
L – Left hand for counterclockwise  
Omit for right hand

# Double Pumps

## Specifications

Based on using petroleum oil at 49° C (120° F), viscosity 32 cSt at 38° C (150 SUS at 100° F), and 0 psi inlet pressure

V2010 model series	Ring size (Delivery USgpm @ 1200 r/min & 100 psi)	Displ. cm <sup>3</sup> /r (in <sup>3</sup> /r)	Max. speed r/min	Maximum pressure bar (psi)	Typical delivery L/min (USgpm) @ max. speed & pressure	Typical input power kW (hp) @ max. speed & pressure	Approx. total weight kg (lb)
Shaft-end pump	6	19,5 (1.19)	3000	172 (2500)	54,9 (14.5)	18,3 (24.5)	13,6 (30)
	7	22,8 (1.39)	3000	172 (2500)	62,5 (16.5)	22,4 (30)	
	8	26,5 (1.62)	2800	172 (2500)	66,2 (17.5)	24,2 (32.5)	
	9	29,7 (1.81)	2800	172 (2500)	75,7 (20)	26,8 (36)	
	11	36,4 (2.22)	2500	172 (2500)	87,1 (23)	28 (37.5)	
	12	39 (2.38)	2400	152 (2200)	87,1 (23)	26,8 (36)	
	13	42,4 (2.59)	2400	152 (2200)	98,4 (26)	29,1 (39)	
Cover-end pump	1	3,3 (.20)	3000	172 (2500)	7,6 (2)	3,4 (4.5)	
	2	6,6 (.40)	3000	172 (2500)	17,8 (4.7)	6,7 (9)	
	3	9,8 (.60)	3000	172 (2500)	26,5 (7)	10 (13.4)	
	4	13,1 (.80)	3000	172 (2500)	36 (9.5)	13,4 (18)	
	5	16,4 (1.00)	3000	172 (2500)	45,4 (12)	16 (21.5)	
	6	19,5 (1.19)	3000	152 (2200)	54,9 (14.5)	18,3 (24.5)	
	7	22,8 (1.39)	2800	138 (2000)	60,6 (16)	17,9 (24)	

See page 4 speed correction curve.

V2020 model series	Ring size (Delivery USgpm @ 1200 r/min & 100 psi)	Displ. cm <sup>3</sup> /r (in <sup>3</sup> /r)	Max. speed r/min	Maximum pressure bar (psi)	Typical delivery L/min (USgpm) @ max. speed & pressure	Typical input power kW (hp) @ max. speed & pressure	Approx. total weight kg (lb)
Shaft-end pump	12	39 (2.38)	2400	152 (2200)	87,1 (23)	26,8 (36)	15,9 (35)
	13	42,4 (2.59)	2400	152 (2200)	98,4 (26)	29,1 (39)	
Cover- or shaft-end pump	6	19,5 (1.19)	3000	172 (2500)	54,9 (14.5)	19,4 (26)	
	7	22,8 (1.39)	3000	172 (2500)	62,5 (16.5)	22,4 (30)	
	8	26,5 (1.62)	2800	172 (2500)	66,2 (17.5)	24,2 (32.5)	
	9	29,7 (1.81)	2800	172 (2500)	75,7 (20)	26,8 (36)	
	11	36,4 (2.22)	2500	172 (2500)	87,1 (23)	28 (37.5)	

See page 4 speed correction curve.

# Double Pumps

## V2010 & V2020 Shaft-end Pump Performance

Oil temp. 49°C (120°F), viscosity  
32 cSt (150 SUS) @ 38°C (100°F),  
inlet pressure zero

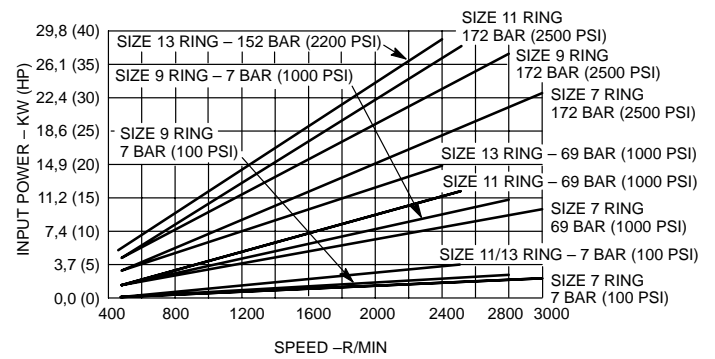
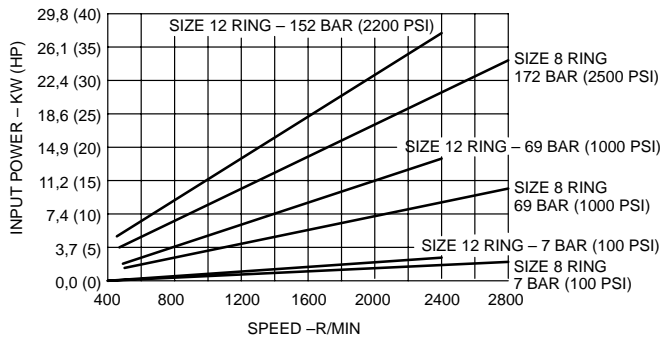
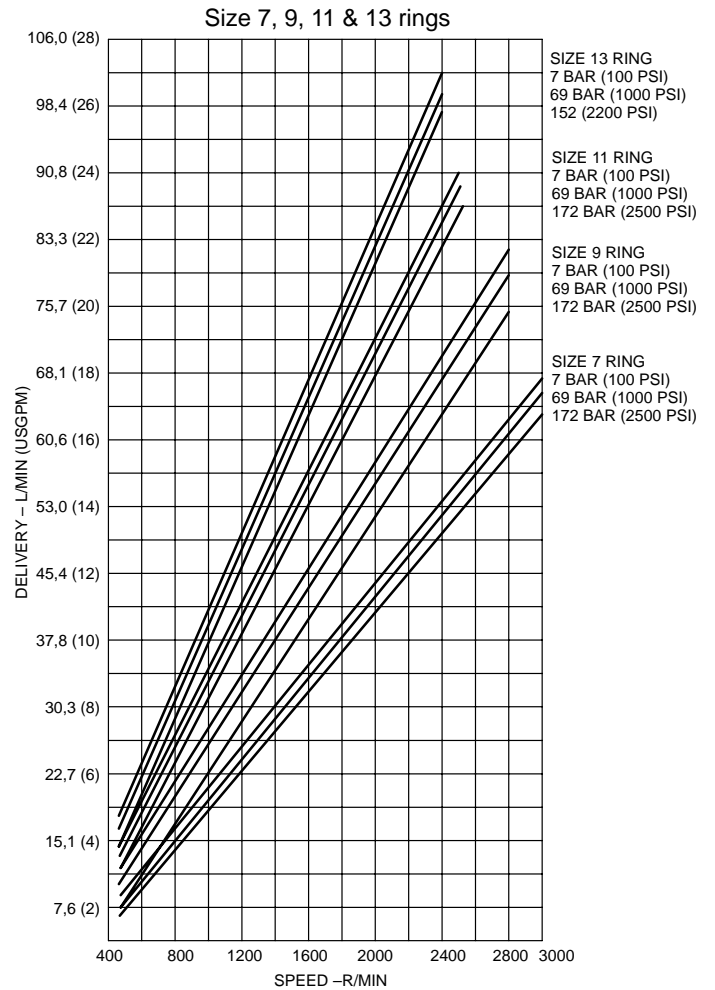
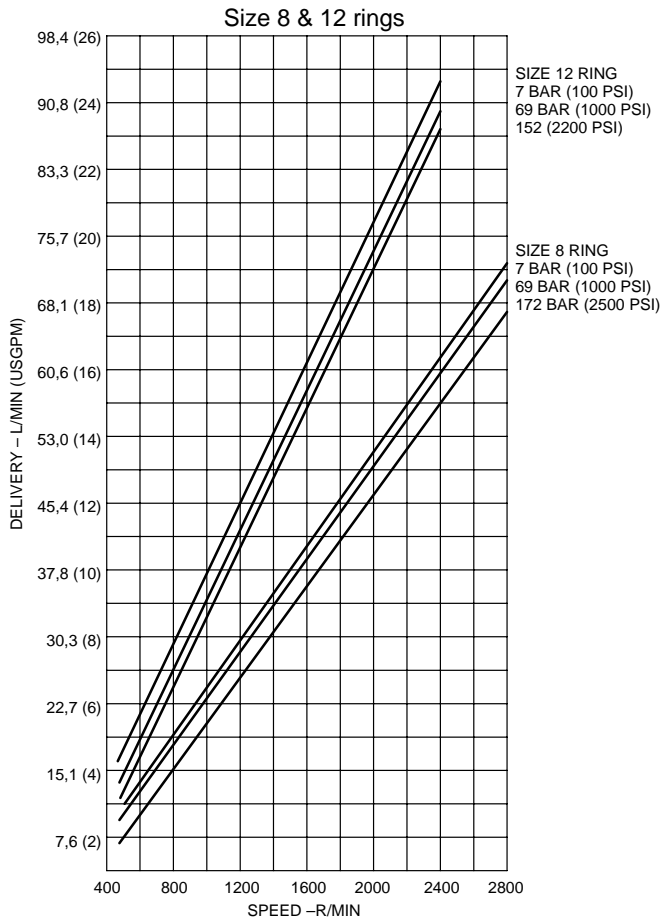

# Double Pumps

## V2010 Cover-end Pump Performance

Oil temp. 49°C (120°F), viscosity  
32 cSt (150 SUS) @ 38°C (100°F),  
inlet pressure zero

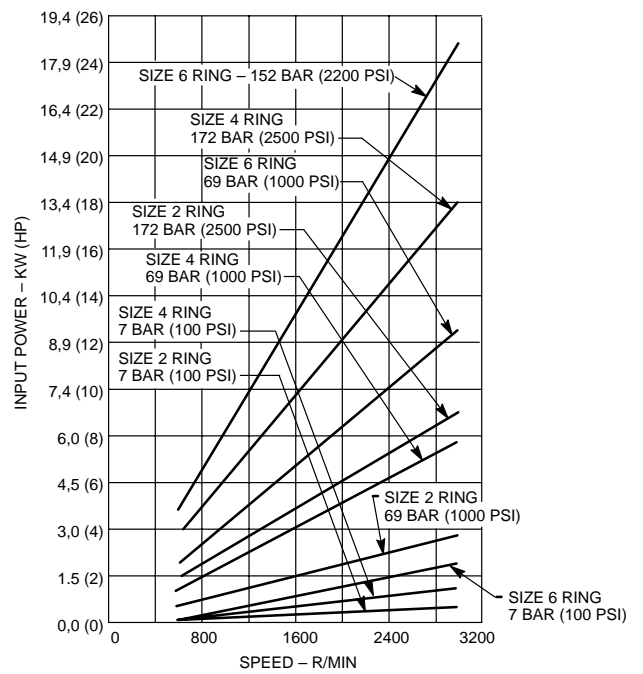
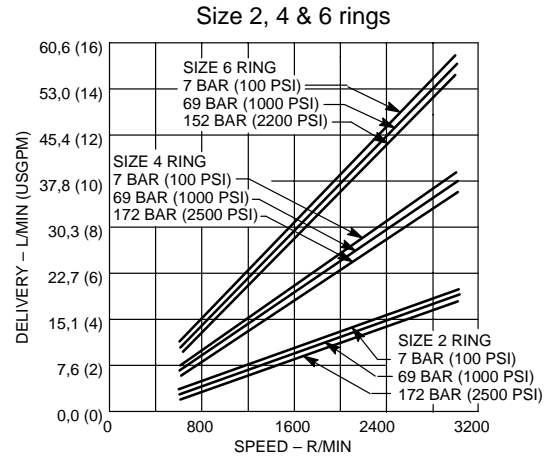
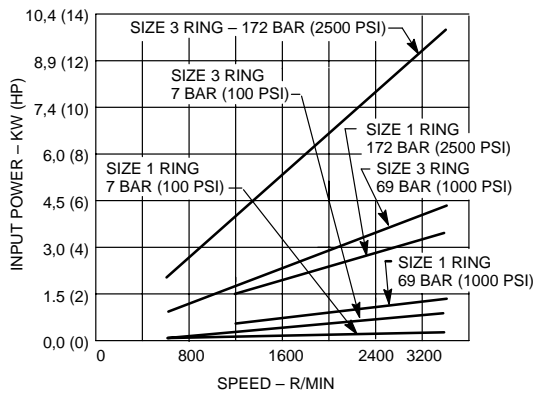
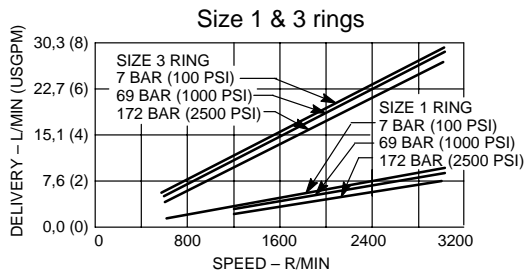



# Double Pumps

## V2010 Cover-end Pump Performance

Oil temp. 49°C (120°F), viscosity  
 32 cSt (150 SUS) @ 38°C (100°F),  
 inlet pressure zero

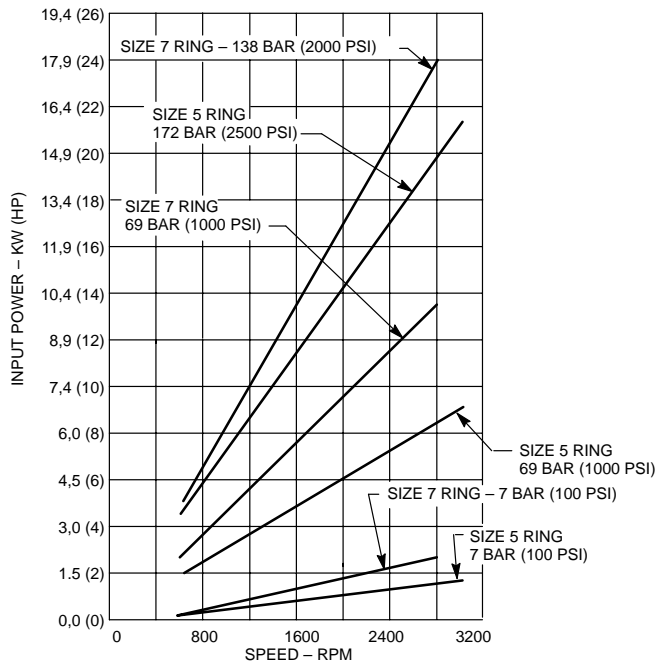
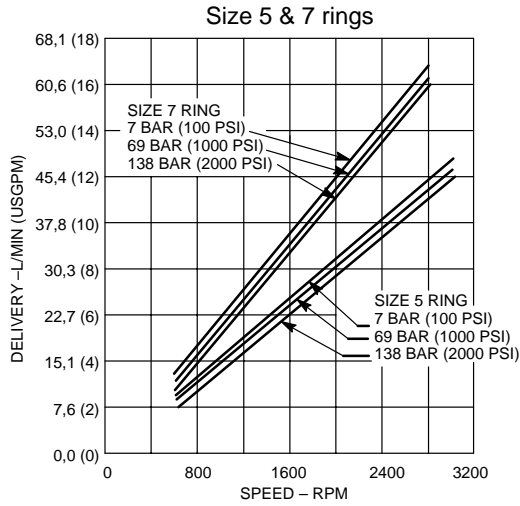

# Double Pumps

## V2020 Cover-end Pump Performance

Oil temp. 49°C (120°F), viscosity  
32 cSt (150 SUS) @ 38°C (100°F),  
inlet pressure zero

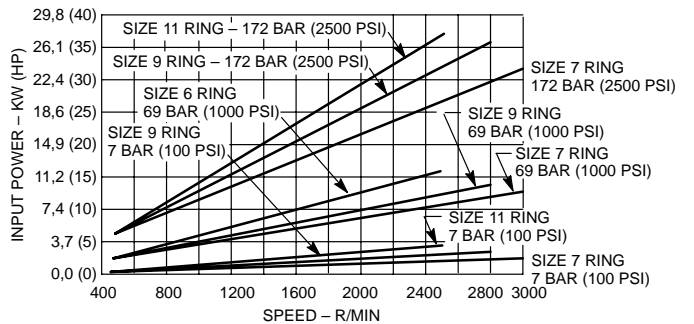
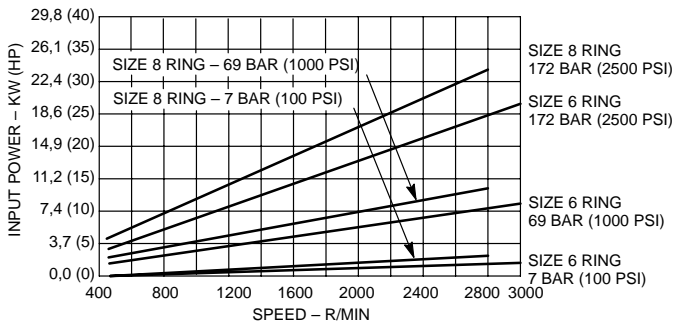
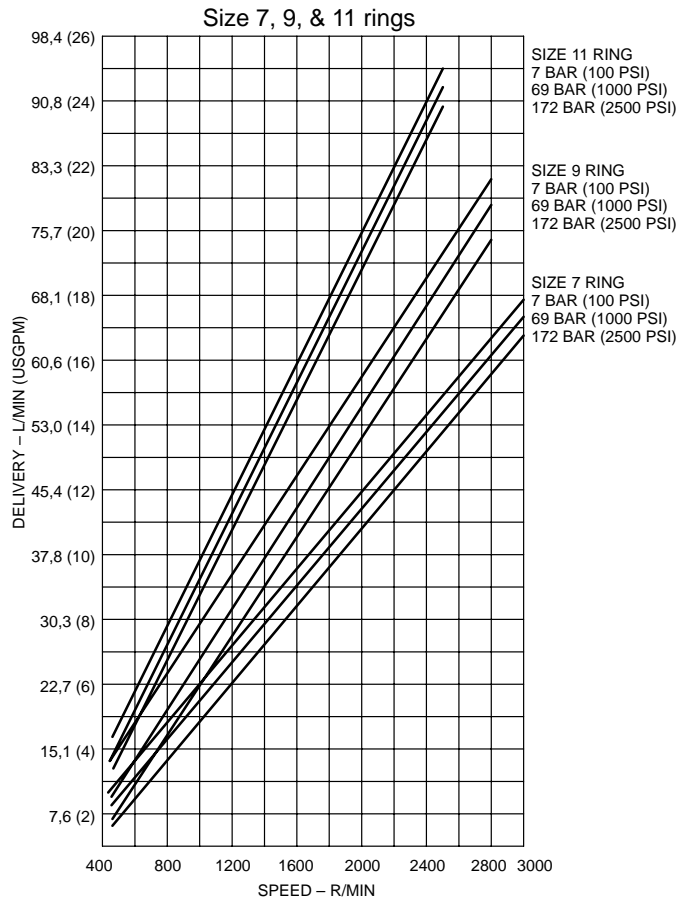
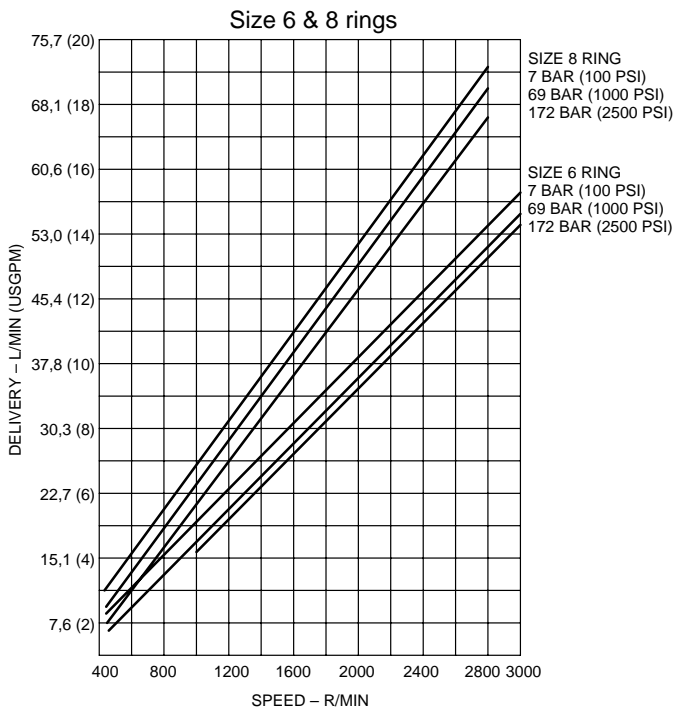

# Double Pumps

## V2010 Dimensions

### Millimeters (inches)

See page 21 for foot mounting dimensions.

Rated Delivery, gpm @ 1200 rpm & 100 psi		Dimensions		
Shaft end	Cover end	A	B	C
7,8 or 9	1, 2 or 3	213,1 (8.39)	189,2 (7.45)	113,3 (4.46)
7,8 or 9	4 or 5	219,5 (8.64)	195,6 (7.70)	113,3 (4.46)
7,8 or 9	6 or 7	224,5 (8.84)	200,7 (7.90)	113,3 (4.46)
11	1, 2 or 3	218,2 (8.59)	194,3 (7.65)	118,1 (4.65)
11	4 or 5	224,5 (8.84)	200,7 (7.90)	118,1 (4.65)
11	6 or 7	229,6 (9.04)	205,7 (8.10)	121,7 (4.79)
12 or 13	1, 2 or 3	221,7 (8.73)	197,9 (7.79)	121,7 (4.79)
12 or 13	4 or 5	227,8 (8.97)	204,0 (8.03)	121,7 (4.79)
12 or 13	6 or 7	232,9 (9.17)	209,0 (8.23)	121,7 (4.79)

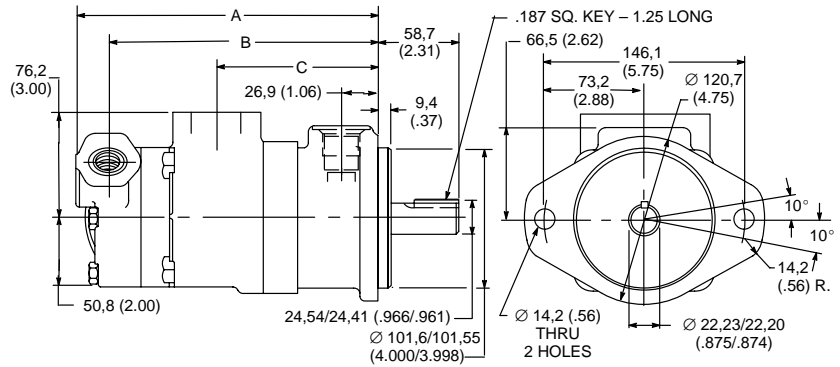
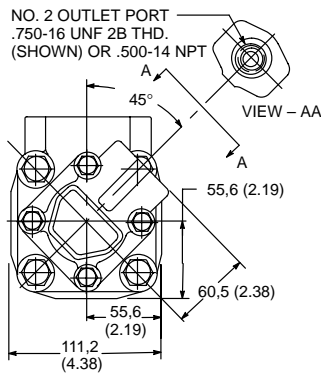
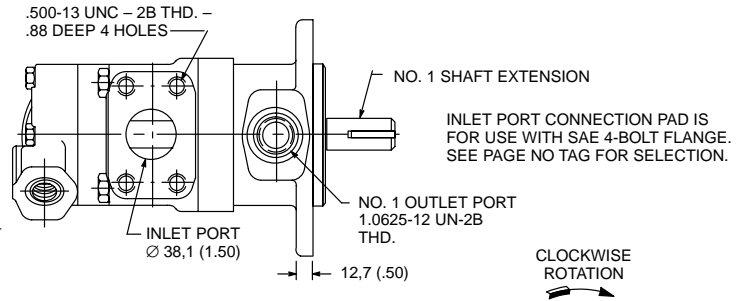

### Number 11 shaft

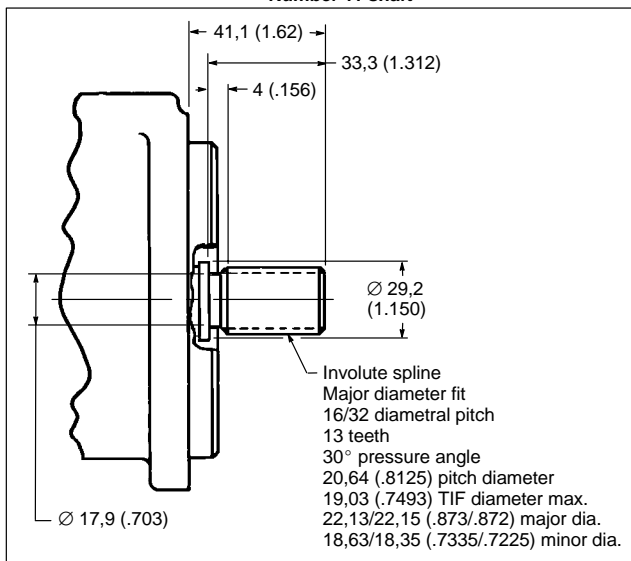

# Double Pumps

## V2020 Dimensions

### Millimeters (inches)

See page 21 for foot mounting dimensions.

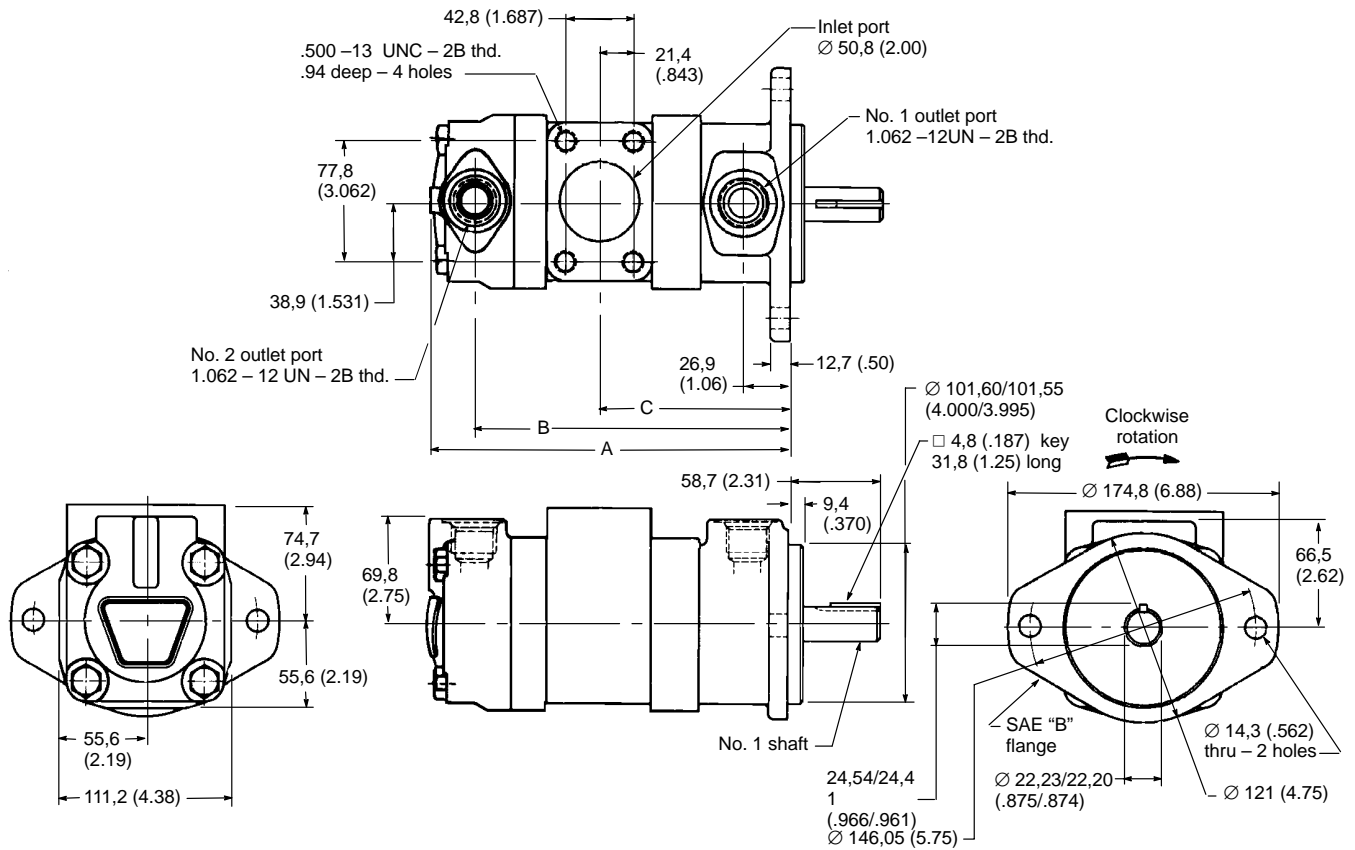

Number 11 shaft

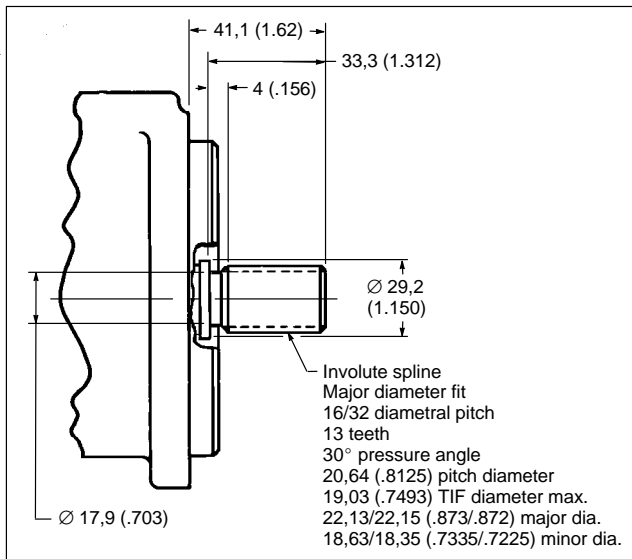

Ring size		Dimensions		
Shaft end	Cover end	A	B	C
7, 8 or 9	6	213,6 (8.41)	187,7 (7.39)	114 (4.49)
7, 8 or 9	7, 8 or 9	220 (8.66)	194 (7.64)	114 (4.49)
11	6	218,7 (8.61)	192,8 (7.59)	119,1 (4.69)
11	7, 8 or 9	225 (8.86)	199,1 (7.84)	119,1 (4.69)
11	11	229,9 (9.05)	204 (8.03)	119,1 (4.69)
12 or 13	6	222,2 (8.75)	196,3 (7.73)	122,4 (4.82)
12 or 13	7, 8 or 9	228,3 (8.99)	202,4 (7.97)	122,4 (4.82)
12 or 13	11	233,4 (9.19)	207,5 (8.17)	122,4 (4.82)

# Foot Bracket Kit

## Dimensions

Millimeters (inches)

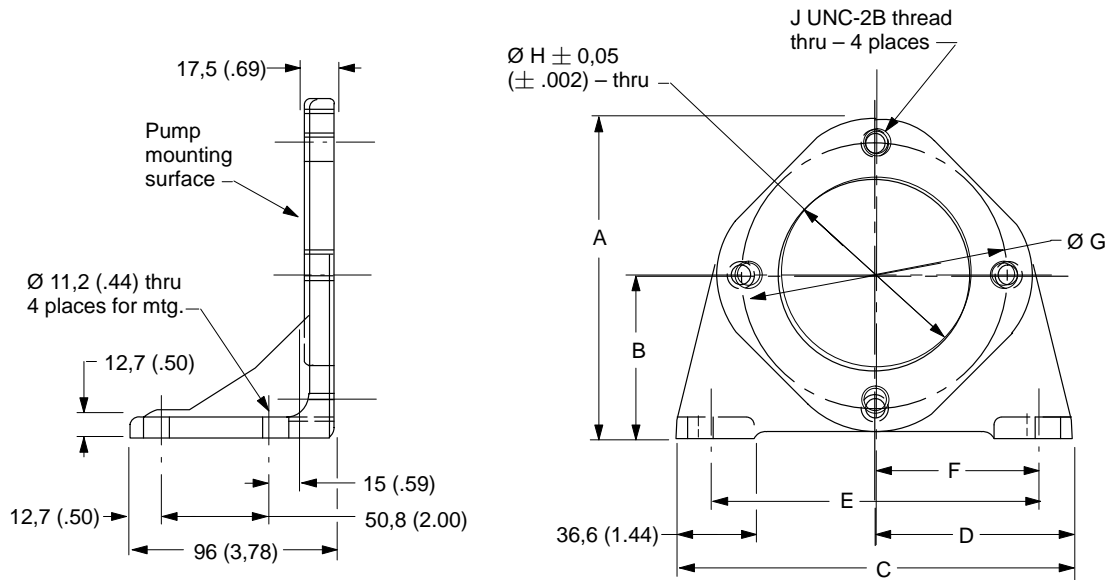

Note: Each kit includes screws for mounting pump to bracket.

Model	A	B	C	D	E	F	$\varnothing G$	$\varnothing H$	J
FB-A-10	134,9 (5.31)	69,8 (2.75)	152,4 (6.00)	76,2 (3.00)	127,0 (5.00)	63,5 (2.50)	106,37 (4.188)	82,63 (3.253)	.375-16
FB-B-10	180,8 (7.12)	92,2 (3.63)	171,4 (6.75)	85,7 (3.38)	146,0 (5.75)	73,1 (2.88)	146,0 (5.75)	101,68 (4.003)	.500-13

# Application and Service Information

## Minimum Speed

Minimum recommended starting speed is generally 600 r/min. However, the pump size, system characteristics and environmental conditions can raise or lower this speed. A lower speed can often be achieved after the pump has primed.

If low starting or operating speeds are required, consult your Vickers representative.

## Inlet Pressure

Recommended inlet pressure is 0 to 0,34 bar (0 to 5 psi) gauge at maximum operating speeds. Inlet pressure should not exceed 0,69 bar (10 psi). Inlet depressions should not exceed 5 inches of Hg with petroleum oil, or 3 inches of Hg with all other fluids.

A pressurized reservoir system does not always assure a positive (supercharge) pressure at the pump inlet. Vacuum at the pump inlet can result during cold start-ups. Avoid high speeds until the circuit has warmed and supercharge pressure actually exists at the pump inlet.

## Drives

Vickers pumps are designed for use on direct coaxial drives. If drives imposing radial or axial loads are being considered, consult your Vickers representative for additional information.

Concentricity and angular alignment of shafts are important to pump life. Misalignment can induce heavy loads on bearings, causing premature failure.

Flexible coupling halves must be aligned according to the coupling manufacturer's recommendations.

When using double universal joint couplings, the shafts must be parallel and the yokes must be in line. The offset should be kept as low as possible. Maximum allowable offset will, of course, vary with application conditions. The pump shaft to universal joint diametral fit should be close (major diameter fit) with no looseness.

## Mounting Dimensions

Concentricity of the customer's female pilot diameter relative to the effective axis of the female drive must be within 0,10 mm (.004 in.) total indicator reading. The clearance between the male and female pilot diameters must be +0,01 to +0,05 mm (+.0005 to +.0020 in.).

The customer's mounting face to which the pump is affixed must be square to the axis of the female drive within 0,04 mm per mm (.0015 in. per in.).

Dimensions of the customer's keyed shaft receiver must be between +0,003 and +0,025 mm (+.0001 and +.0010 in.) of the maximum shaft diameter shown on the Vickers installation drawing.

## Valves and Circuitry

Protect against hydraulic surge pressures (inlet or outlet) applied to or generated by the pump. Relief valves must prevent these surges from exceeding published pressure ratings.

Never assume a relief valve setting is the maximum pressure a pump experiences. Shock conditions may exist which can exceed circuit and pump limitations.

## Shaft Loading

Never assume pumps in a double pump assembly can be simultaneously loaded to rated pressure. Shaft loading must be checked for excessive torque and side loads.

## Piping

Hydraulic lines should be as short and have as large an inside diameter as possible. Where lines are long, it is desirable to adapt to a larger capacity line than a unit's ports specify. Inlet, outlet and drain lines should not be smaller than the nominal port size shown on installation drawings. A "Y" shaped inlet should not be used to feed two separate pumps because one may be starved and cavitate.

There should be as few bends and fittings in lines as possible. High-pressure lines and fittings are restrictive to flow and may result in excessive pressure drop through the system. They should be used only where necessary in a pressure line.

## Hose

When installing a hose, allow enough slack to avoid kinking. A taut hose will not allow movement with pressure surges. Slack in the line compensates for surges, relieving strain. The hose should not be twisted during installation or while in operation. Twisting will weaken the hose and loosen connections.

A neater installation is usually obtainable by using extra fittings to minimize unusually long loops in a line. Hoses should be clamped to prevent rubbing and entanglement with moving parts. Where hoses are subject to chafing, they should be run through protective neoprene hose or shielded metallic guards.

# Application and Service Information

## Hydraulic Fluids

Pumps can be used with anti-wear hydraulic oil, or automotive type crankcase oil (designations SC, SD, SE, SF, or SG) per SAE J183 JUN89. Fire-resistant fluids can also be used, but may require the use of special seals as explained in the following “Seals” section.

The viscosity range of petroleum oil, with the pump running, should be 13-54 cSt (70-250 SUS). The oil viscosity at 38°C (100°F) should be 32-48 cSt (150-225 SUS).

Fire-resistant fluids should have a viscosity as close as possible to that of petroleum oil as described above. A maximum specific gravity of 1.3 is suggested for fire-resistant fluids.

An operating temperature of 49°C (120°F) is recommended. The maximum temperature for oil should be 65°C (150°F), and the maximum for water-containing fluids should be 130°F.

For additional fluid and temperature information, refer to 694.

## Seals

Nitrile seals are standard and are suitable for use with petroleum, water-glycol, water-in-oil emulsion, polyol ester, and high-water-base fluids. Phosphate ester fluids require the use of fluorocarbon seals, which are identified in model codes as an “F3” prefix.

## Fluid Cleanliness

Proper fluid condition is essential for long and satisfactory life of hydraulic components and systems. Hydraulic fluid must have the correct balance of cleanliness, materials and additives for protection against wear of components, elevated viscosity and inclusion of air.

Essential information on the correct methods for treating hydraulic fluid is included in Vickers publication 561; “Vickers Guide to Systemic Contamination Control,” available from your local Vickers distributor or by contacting Vickers, Incorporated. Recommendations on filtration and the selection of products to control fluid condition are included in 561.

Recommended cleanliness levels, using petroleum oil under common conditions, are based on the highest fluid pressure levels in the system and are coded in the chart below. Fluids other than petroleum, severe service cycles, or personnel safety considerations are cause for adjustment of these cleanliness codes. See Vickers publication 561 for exact details

Vickers products, as any components, will operate with apparent satisfaction in fluids with higher cleanliness codes than those described. Other manufacturers will often recommend levels above those specified. Experience has shown, however, that life of any hydraulic components is shortened in fluids with higher cleanliness codes than those listed below. These codes have been proven to provide a long trouble-free service life for the products shown, regardless of the manufacturer.

Product	System Pressure Level – bar (psi)		
	<70 ( <1000)	70-210 (1000-3000)	210+ (3000+)
<b>Vane Pumps – Fixed</b>	<b>20/18/15</b>	<b>19/17/14</b>	<b>18/16/13</b>
Vane Pumps – Variable	18/16/14	17/15/13	
Piston Pumps – Fixed	19/17/15	18/16/14	17/15/13
Piston Pumps – Variable	18/16/14	17/15/13	16/14/12
Directional Valves	20/18/15	20/18/15	19/17/14
Pressure/Flow Control Valves	19/17/14	19/17/14	19/17/14
CMX Valves	18/16/14	18/16/14	17/15/13
Servo Valves	16/14/11	16/14/11	15/13/10
Proportional Valves	17/15/12	17/15/12	15/13/11
Cylinders	20/18/15	20/18/15	20/18/15
Vane Motors	20/18/15	19/17/14	18/16/13
Axial Piston Motors	19/17/14	18/16/13	17/15/12
Radial Piston Motors	20/18/14	19/17/13	18/16/13

# Application and Service Information

## Aeration

Reservoir and circuit design must prevent aeration of the fluid. Particular care must be used to employ joints, seals and gaskets that will not leak or deteriorate. This is especially important in low pressure and suction lines. Connections should always be tight to prevent air from entering the system.

It is best to use windows and sight glasses in the reservoir and inlet lines during prototype evaluation to determine whether significant amounts of air are present in the fluid. Any opaqueness or milky appearance of the fluid in the lines or reservoir indicates excessive aeration. Bubbles on the surface of the reservoir fluid may indicate that excessive aeration is present.

## Reservoir

The oil level of the reservoir should be as high as possible above the pump suction line opening. All return lines should discharge near the tank bottom, always below the oil level, and as far from the pump inlet as possible.

Reservoirs should incorporate a sight gauge, dipstick or other means for easy checking of the oil level. Without these devices, the oil level often goes unchecked and, should a leak occur, the pump can be starved and damaged from loss of lubrication.

Preferably, reservoirs should be located above pumps. This creates a flooded pump inlet which reduces the possibility of pump cavitation.

Pump suction and tank return lines should be attached to the reservoir by flanges or welded heavy-duty coupling. If the suction line is connected to the bottom of the reservoir, the coupling should extend above the bottom inside the tank. This prevents residual dirt from getting into the suction line when the tank is cleaned. The seals used on all suction line connections should be such that they will not deteriorate and leak.

A baffle plate in the reservoir is desirable to separate the suction and return lines. The plate causes return oil to circulate around the outer wall of the reservoir for cooling before it re-enters the pump. It also helps provide time for entrained air to separate from the oil. Baffle plate openings should be designed so that cascade effects and resultant air entrainment are minimized.

Most reservoirs are vented to the atmosphere through an opening that lets air leave or enter the space above the oil as the oil level rises or falls. A filler/breather unit containing an air filtering element is often used as the vent. It must be large enough to handle the air flow required to maintain atmospheric pressure whether the tank is full or empty.

## Startup

Before starting, fill the pump with system fluid through the uppermost port. The housing must be kept full at all times to provide internal lubrication.

At initial startup, it may be necessary to bleed air from the pump outlet to permit priming and reduce noise. Bleed by loosening an outlet connection until a solid stream of fluid appears. An air bleed valve for this purpose is available through your Vickers representative.

## Application Guidance

To ensure optimum pump performance in conjunction with your specific application, consult your Vickers representative if your:

- Application requires an indirect drive
- Fluid does not meet specifications
- Mounting attitude is other than horizontal
- Oil viscosity at operating temperature is not within 13-54cSt (70-250 SUS)
- Oil viscosity at startup is in excess of 220 cSt (1000 SUS)
- Needs require application assistance

## Service Information

Refer to the following drawings for service parts information:

Model Series	Drawing
V10	M-2005-S
V20	M-2004-S
V2010	M-2255-S
V2020	M-2256-S

The overhaul manual for V10 and V20 models is I-3143-S.