

# Medium Duty Piston Motors

## Table of Contents

Features and Introduction .....	3
Application Information .....	3
<b>741XX Models - Fixed Displacement Motor Specifications</b> .....	4
Model 74111 Performance Data, 12,3 cm <sup>3</sup> /r [0.75 in <sup>3</sup> /r] Displacement .....	5
Model 74118 Performance Data, 20,3 cm <sup>3</sup> /r [1.24 in <sup>3</sup> /r] Displacement .....	7
Model Code .....	9
Installation Drawings .....	10-11
<b>743XX Models - Fixed Displacement Motor Specifications</b> .....	12
Model 74315 Performance Data, 32,9 cm <sup>3</sup> /r [2.01 in <sup>3</sup> /r] Displacement .....	13-14
Model 74318 Performance Data, 40,6 cm <sup>3</sup> /r [2.48 in <sup>3</sup> /r] Displacement .....	15-16
Model 74328 Performance Data, 49,2 cm <sup>3</sup> /r [3.0 in <sup>3</sup> /r] Displacement .....	17-18
Model Code .....	19
Installation Drawings .....	20-26
<b>746XX Models - High Torque Fixed Displacement Motor Specifications</b> .....	27
Model 74624 Performance Data, 82,6 cm <sup>3</sup> /r [5.04 in <sup>3</sup> /r] Displacement .....	28-29
Model Code .....	30
Installation Drawings .....	31-33
<b>71392 Model - Variable Displacement Motor Specifications</b> .....	34
71392 Models, 40,6 cm <sup>3</sup> /r [2.48 in <sup>3</sup> /r] Displacement .....	35
Installation Drawings .....	36
<b>72450 Models - Servo Controlled, Variable Displacement Motor Model Code</b> .....	37
Installation Drawings .....	38

# General Overview

## Features

- Compact
- Lightweight Durable Housing
- Numerous Shaft Options
- SAE Mounting Flanges
- SAE O-Ring Porting
- Dual Rotation
- Various Porting Options
- Fixed Displacements

## Introduction

Eaton Medium duty piston motors convert hydraulic energy supplied by the pump to mechanical energy. These motors are uniquely suited to fit any application that requires continuous rotary motion at a remote location from the power source. Axial piston motors share the design advantages of piston pumps to provide long-lasting power in a lightweight, easily serviceable package.

The chart below provides an overview of features. For a complete list of options, refer to the Model Code section of a given motor displacement.

## Application Information

### Case Drain Installation Requirements

CAUTION - Failure to meet these requirements may result in damage to the piston motor.

- Install piston motors in such a position that the case drain assures an oil level at or above unit center line.
- Oil level must be at or above the unit center line before starting the piston motor.
- Provide a case drain line of adequate size to limit the case pressure to specified maximum.

### Cleanliness

In systems using Eaton medium duty piston motors, the fluid must be maintained

at ISO Cleanliness Code 18/13 or better per SAE J1165. This code allows a maximum of 2,500 particles per milliliter greater than 5  $\mu\text{m}$  and a maximum of 80 particles per milliliter greater than 15  $\mu\text{m}$ . When components with different cleanliness requirements are used in the same system, the cleanest standard should be applied.

Fluid Recommendations  
(Refer to Eaton's Hydraulic Fluid Recommendations Technical Data sheet #3-401)

In hydraulic systems using Eaton's medium duty piston pumps and motors, the optimum viscosity range is 10-39 cSt [60-180 SUS], at normal operating temperatures. Viscosity should never fall below 6 cSt [45 SUS].

MOTOR TYPE	MOUNT	MOTOR MODEL	DISPLACEMENT	SHAFT KEYED	SHAFT SPLINE	SHAFT THROUGH	PORTING
Fixed Displacement	"A"	74111	12,3 cm <sup>3</sup> /r [0.75 in <sup>3</sup> /r]	•	•		Same or Opp./Side or Rear
741XX Models	2 Bolt	74118	20,3 cm <sup>3</sup> /r [1.24 in <sup>3</sup> /r]	•	•		Same or Opp./Side or Rear
		74148	20,3 cm <sup>3</sup> /r [1.24 in <sup>3</sup> /r]	•	•	•	Same Side
		74149	12,3 cm <sup>3</sup> /r [0.75 in <sup>3</sup> /r]	•	•	•	Same Side
Fixed Displacement	"B"	74312	32,9 cm <sup>3</sup> /r [2.01 in <sup>3</sup> /r]	•	•		Same or Opp./Side or Rear
743XX Models	2 Bolt	74318	40,6 cm <sup>3</sup> /r [2.48 in <sup>3</sup> /r]	•	•		Same or Opp./Side or Rear
		74328	49 cm <sup>3</sup> /r [3.0 in <sup>3</sup> /r]	•	•		Same or Opp./Side or Rear
		74348	40,6 cm <sup>3</sup> /r [2.48 in <sup>3</sup> /r]	•	•	•	Same Side
Fixed Displacement	"B-B"	74624	82,6 cm <sup>3</sup> /r [5.04 in <sup>3</sup> /r]	•	•		Same Side or Rear
746XX Models	2 Bolt	74644	82,6 cm <sup>3</sup> /r [5.04 in <sup>3</sup> /r]	•	•	•	Same Side or Rear
Variable Displacement	SAE "B"	71392	40,6 to 21,0 cm <sup>3</sup> /r [2.48 to 1.28 in <sup>3</sup> /r]	•	•		Opposite Side or Rear
Servo Control 72450	"B"	72450	40,6 to 21,0 cm <sup>3</sup> /r [2.48 to 1.28 in <sup>3</sup> /r]	•	•	•	Same Side
Variable Displacement	2 Bolt SAE	72450	49,2 to 24,6 cm <sup>3</sup> /r [3.0 to 1.5 in <sup>3</sup> /r]	•	•	•	Same Side

# 741XX Models

2Bolt SAE "A" Mount

12,3 cm<sup>3</sup>/r [.75 in<sup>3</sup>/r]

Displacement

20,3 cm<sup>3</sup>/r [1.24 in<sup>3</sup>/r]

Displacement

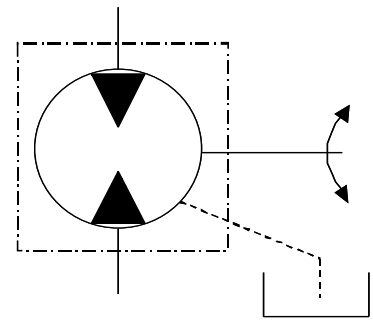

TYPICAL PRODUCT NUMBER	MODEL CODE
74111-DAC-01	AAVAAAA0B000A0B
74111-DAF-01	AAVAEAA0B000A0B
74111-DAS-01	AAVAABA0B000A0B
74111-DAU-01	AAVAEBA0B000A0B
74115-DAC-01	AAVAEAA0A000A0B
74115-DAF-01	AAVAABA0A000A0B
74118-DAJ-01	AAVAAAA00000A0B
74118-DAS-01	AAVAAAB00000A0B
74118-DBJ-01	AAVAAAC00000A0B
74118-DAP-01	AAVAEAA00000A0B
74118-DBA-01	AAVAABA00000A0B
74118-DBH-01	AAVAEBA00000A0B
74148-DAF-01	AAVAECC10000A0B



SPECIFICATIONS	MODEL 74111/74119	MODEL 74118/74148
Maximum Displacement	12,3 cm <sup>3</sup> /r [.75 in <sup>3</sup> /r]	20,3 cm <sup>3</sup> /r [1.24 in <sup>3</sup> /r]
Maximum Rated Speed	4500 RPM	3600 RPM
Continuous Rated Pressure †	210 bar [3000 lbf/in <sup>2</sup> ]	210 bar [3000 lbf/in <sup>2</sup> ]
Maximum Rated Pressure ††	345 bar [5000 lbf/in <sup>2</sup> ]	345 bar [5000 lbf/in <sup>2</sup> ]
Maximum Intermittent Pressure †††	370 bar [5400 lbf/in <sup>2</sup> ]	370 bar [5400 lbf/in <sup>2</sup> ]
Input Flow at Rated Speed and Pressure	64 l/min [16.9 GPM]	79 l/min [20.8 GPM]
Output Power at Rated Speed and Pressure	13,8 kW [18.5 hp]	23,2 kW [31.1 hp]
Output Torque at Rated Speed and Pressure	29 N•m [260 lbf•in]	62 N•m [550 lbf•in]
Continuous Allowable Case Pressure	1,7 bar [25 lbf/in <sup>2</sup> ]	1,7 bar [25 lbf/in <sup>2</sup> ]
Continuous Inlet Temperature	107°C [225°F]	107°C [225°F]
Weight/Single Motor (approximate)	4,9 kg [11 lbs]	4,9 kg [11 lbs]

† Continuous Rated Pressure - Motor may run uninterrupted at this pressure.  
 †† Maximum Rated Pressure - Highest allowable system pressure. (High pressure relief valve setting)  
 ††† Maximum Intermittent Pressure - A pressure spike only for a short period of time, not continuous.

# Model 74111 & 74149

## Performance Data

The charts below are representative of a 12,3 cm<sup>3</sup>/r [.75 in<sup>3</sup>/r] displacement piston motor. The tests were run at an oil temperature of 80o C [180oF] with viscosity 7-9 cSt [50-54 SUS].

### Overall Efficiency

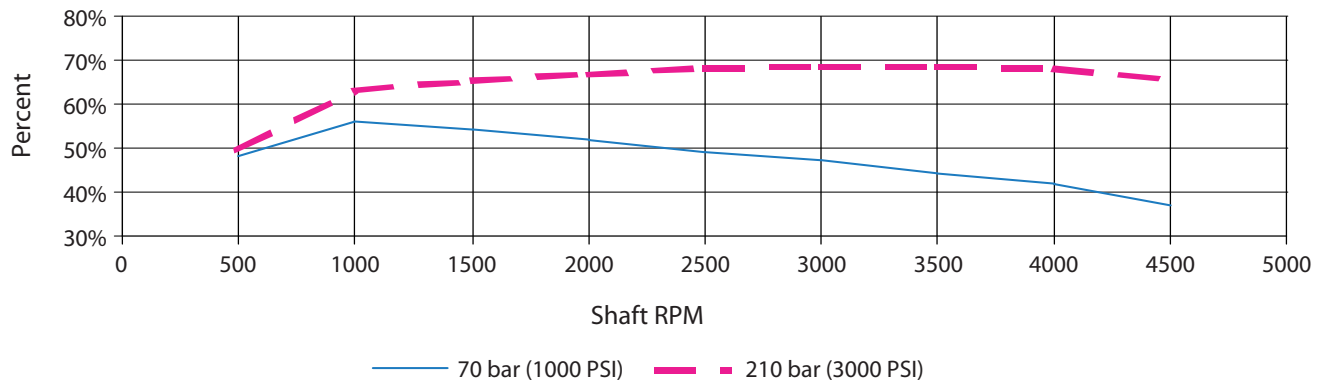

### Volumetric Efficiency

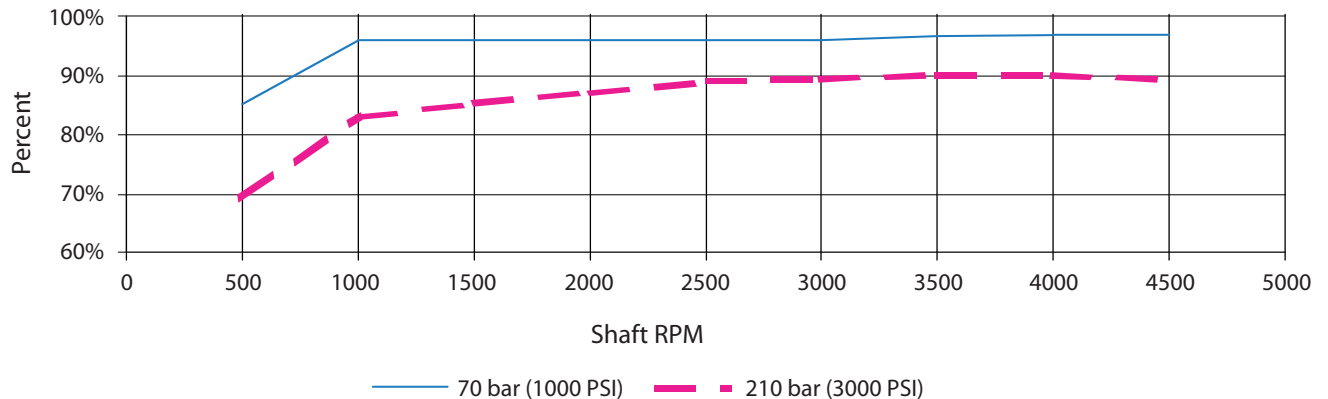

# Model 74111 & 74149

## Performance Data

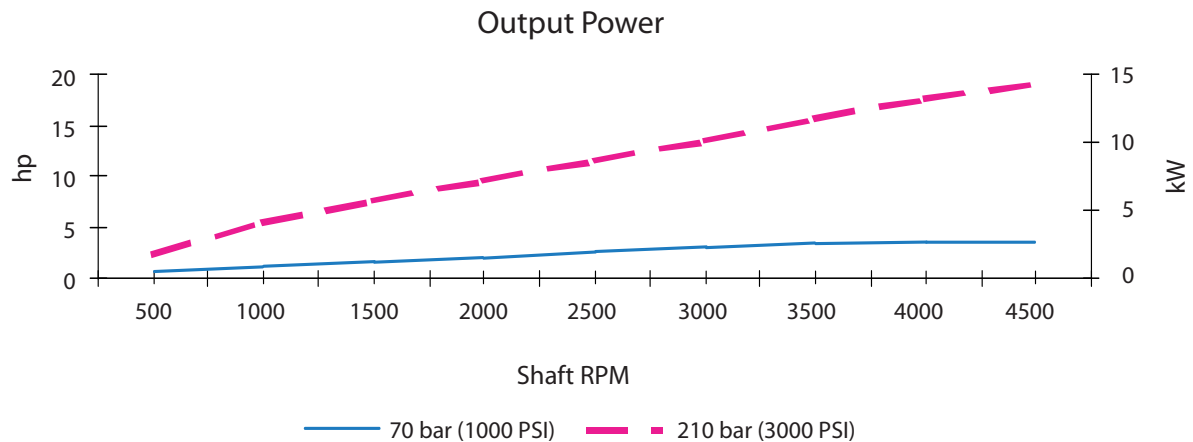
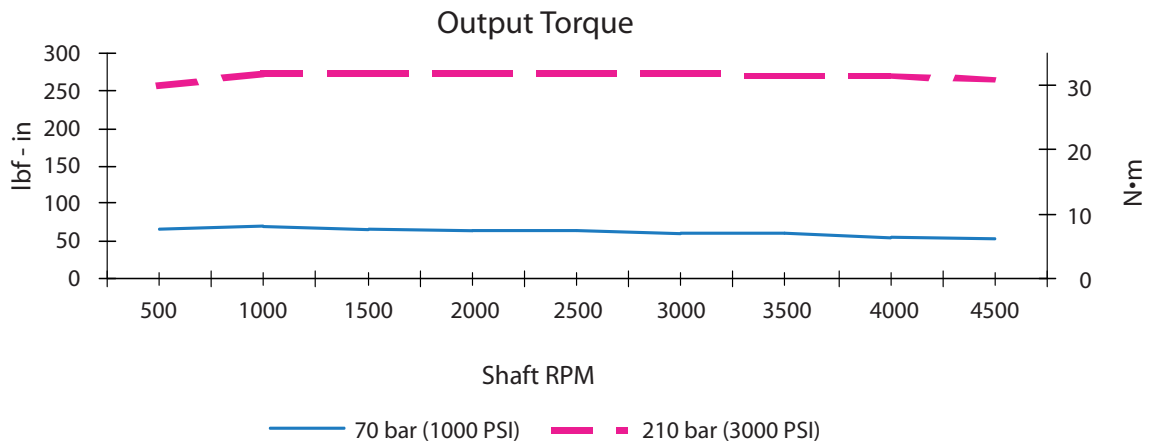
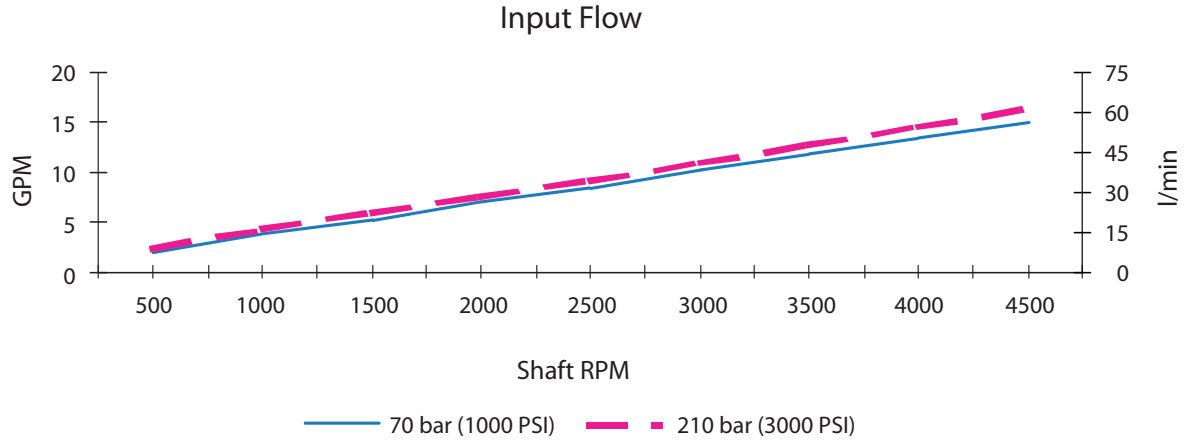

# Model 74118 & 74148

## Performance Data

The charts below are representative of a 20,3 cm<sup>3</sup>/r [1.24 in<sup>3</sup>/r] displacement piston motor. The tests were run at an oil temperature of 80o C [180oF] with viscosity 7-9 cSt [50-54 SUS].

### Overall Efficiency

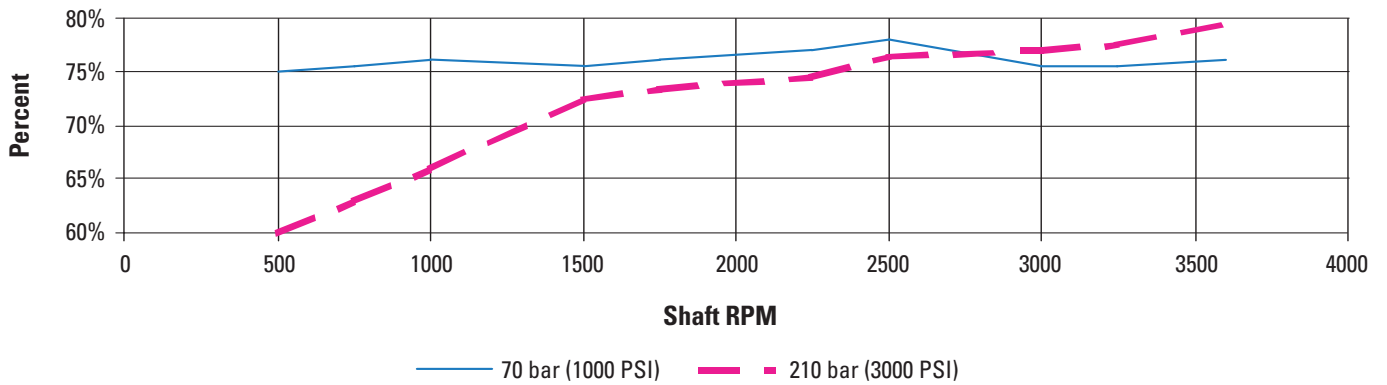

### Volumetric Efficiency

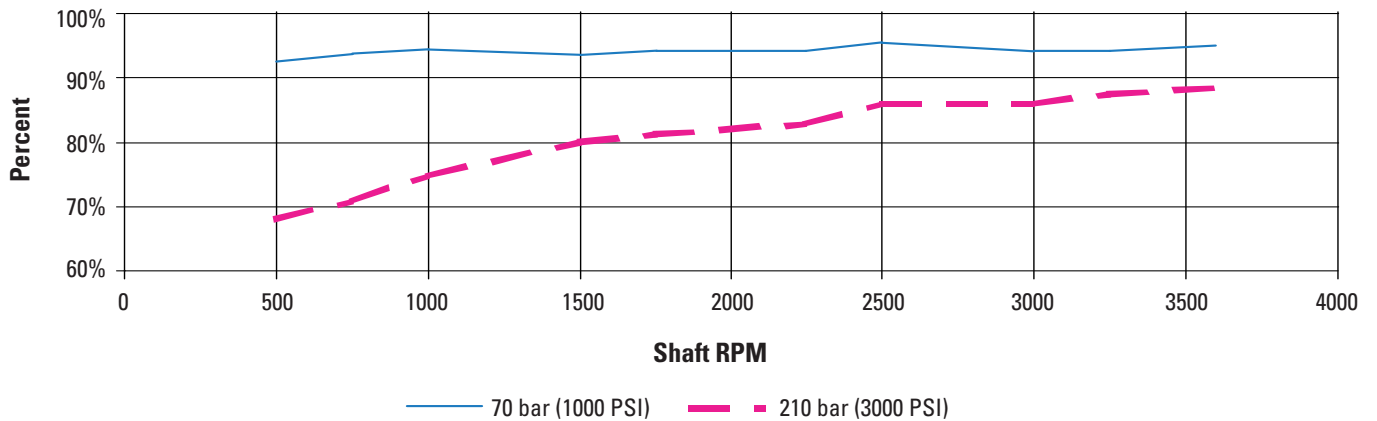

# Model 74118 & 74148

## Performance Data

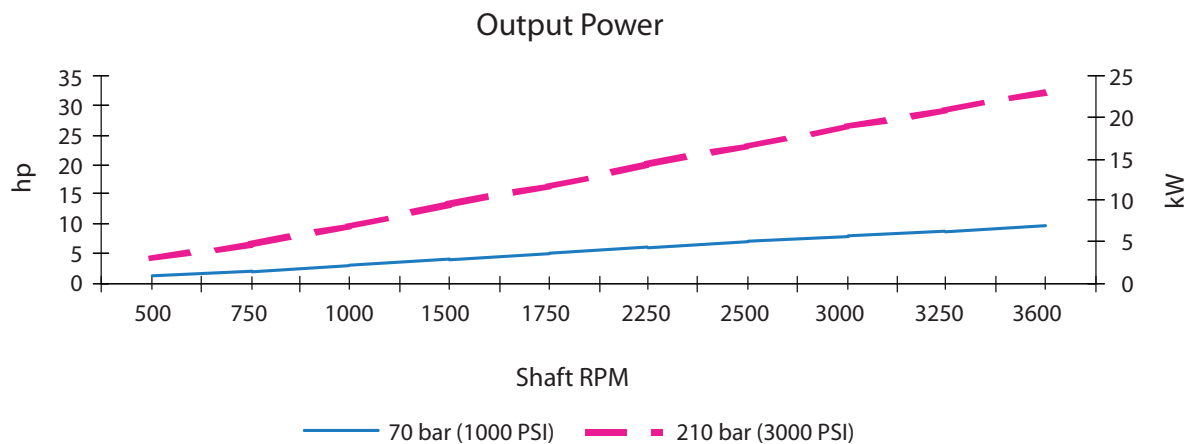
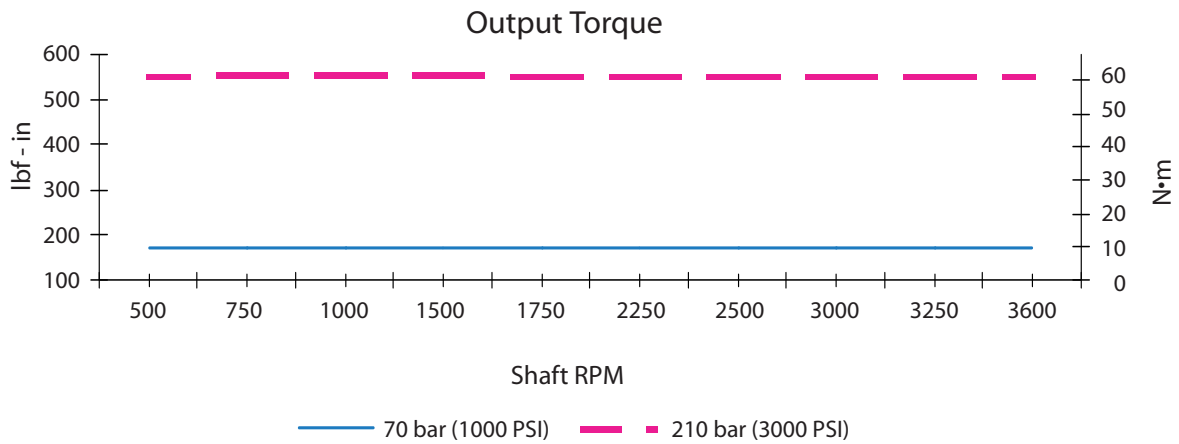
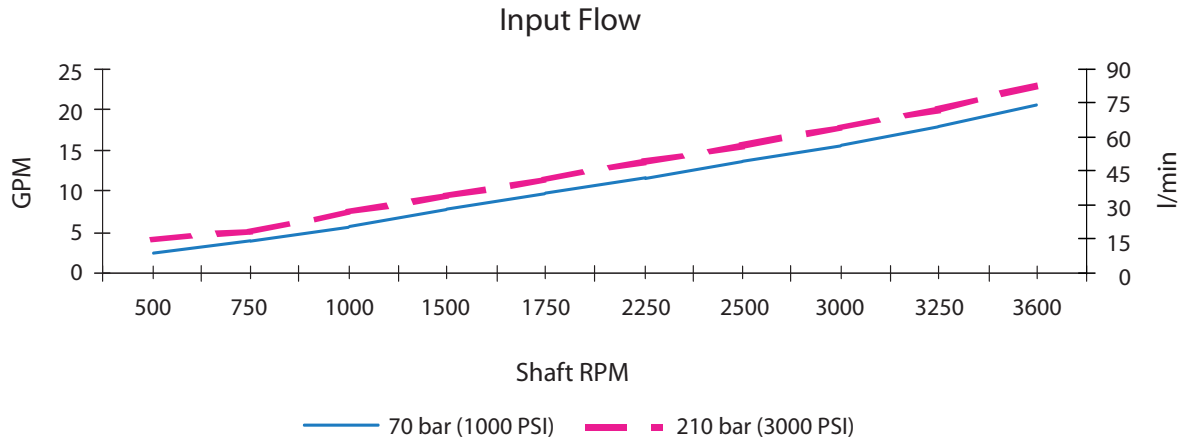

# Fixed Displacement Motor 741XX Model Code

12,3 cm<sup>3</sup>/r [1.75 in<sup>3</sup>/r]

Displacement

20,3 cm<sup>3</sup>/r [1.24 in<sup>3</sup>/r]

Displacement

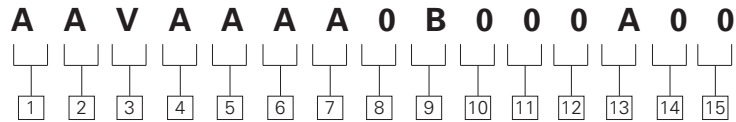

**1 2 3 Code Title**  
**AAV** - 20,3 cm<sup>3</sup>/r [1.24 in<sup>3</sup>/r]  
 Fixed displacement  
 piston motor frame size

**4 5 Output Shaft**  
**AA** - 13 Tooth 16/32 spline  
 with snap ring groove,  
 min. full spline 22,1  
 [.87], shaft  
 extension 41,1 [1.62],  
 (std.)  
**AE** - Straight shaft, dia. 22,2  
 [.875], keyway 6,35  
 [.25] x 25,6 [.97], shaft  
 extension 41,1 [1.62]  
 (key included), (std.)

**6 Main Port, Size, & Location**  
**A** - 1-1/16-12 UN-2B  
 straight thread o-ring-  
 ports- opposite sides,  
 (std.)  
**B** - 1-1/16-12 UN-2B  
 straight thread o-ring  
 ports- rear, (std.)  
**C** - 1-1/16-12 UN-2B  
 straight thread o-ring  
 ports- same side, only  
 with through shaft,  
 (opt.)

**7 Drain Port, Size, & Location**  
**A** - 9/16-18 UNF-2B straight  
 thread o-ring port -  
 upper rear, (std.)  
**B** - 9/16-18 UNF-2B straight  
 thread o-ring port -  
 lower rear, (std.)  
**C** - 9/16-18 UNF-2B straight  
 thread o-ring port - bot-  
 tom rear, with through  
 shaft only (pos. 8,  
 selection 1), (std.)

**8 Auxiliary Mounting Features (rear)**  
**0** - No Auxiliary Mounting  
 Feature  
**1\*** - Straight through shaft,  
 dia. 19 [.75], with key-  
 way 4,8 x 31 [.189 x  
 1.22]. 209, 3 [8.42] from  
 mounting flange (Key  
 included), 5/16 - 18  
 UNC-2B mounting holes  
 14, 2 [.56] deep min.  
 full thread, (opt.)

**9 Drain Port, Size, & Location**  
**0** - As given in code title. -  
 Model 74118 or 74148,  
 (std.)  
**A** - 16,6 cm<sup>3</sup>/r [1.01 in<sup>3</sup>/r]  
 destroked from 20,3  
 cm<sup>3</sup>/r [1.24 in<sup>3</sup>/r], (opt.)  
**B** - 12,3 cm<sup>3</sup>/r [.75 in<sup>3</sup>/r]  
 destroked from 20,3  
 cm<sup>3</sup>/r [1.24 in<sup>3</sup>/r] - Model  
 74111 or 74149, (std.)  
**C** - 9,8 m<sup>3</sup>/r [.60 in<sup>3</sup>/r]  
 destroked from 20,3  
 cm<sup>3</sup>/r [1.24] in<sup>3</sup>/r, (opt.)  
**D** - 14,96 m<sup>3</sup>/r [.91 in<sup>3</sup>/r]  
 destroked from 20,3  
 cm<sup>3</sup>/r [1.24] in<sup>3</sup>/r, (opt.)

**10 11 Special Features**  
**00** - No Special Features, (std.)

**12 13 Paint**  
**0A** - Primer, (std.)  
**0B** - Black Paint, (std.)

**14 Identification**  
**0** - Standard, (std.)

**15 Design Code**  
**0** - Eaton assigns current  
 design code, (std.)

**Fixed displacement piston motors are specified by the following model code. Once a motor is built from the model code, a product number will be assigned to that configuration. Make sure all positions are selected within the 15 digit code for each motor.**



# Model 74111 & 74118

## Installation Drawings

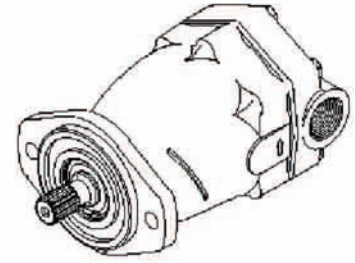

### Opposite Side Porting

(Code position 6, Section A)

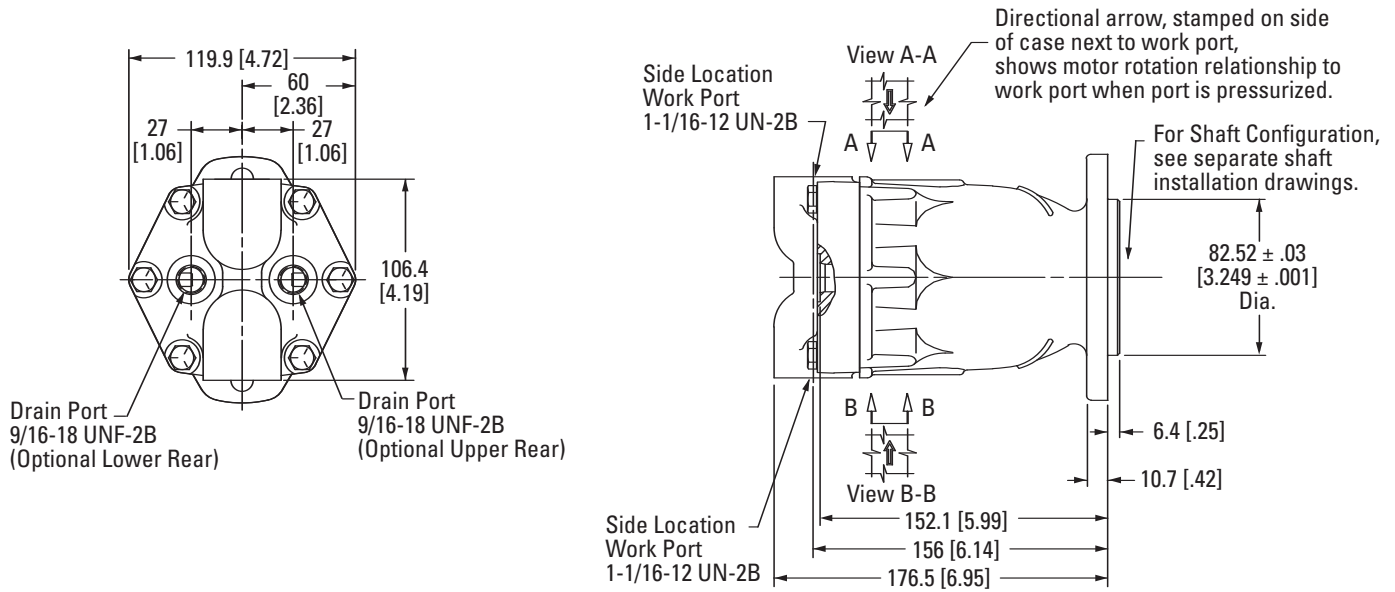

### Rear Porting

(Code position 6, Section B)

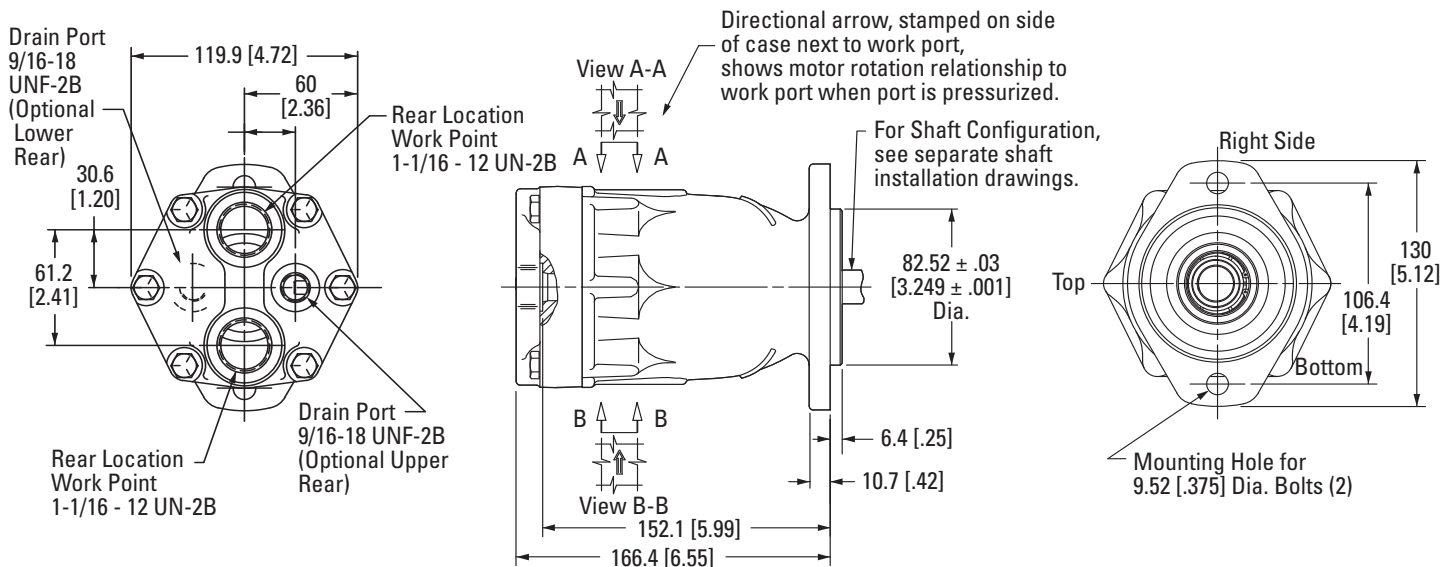

**Note: All ports are SAE (J1926) o-ring ports. Dimensions are in millimeters [inches], unless otherwise specified.**

# Model 74148 & 74149

## Installation Drawings

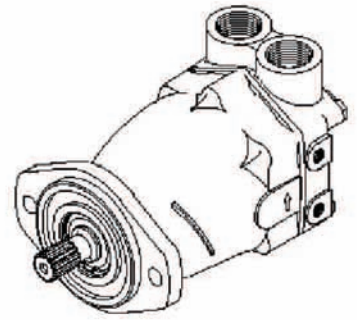

### Through Shaft and Same Side Porting

(Code position 6, Section C)

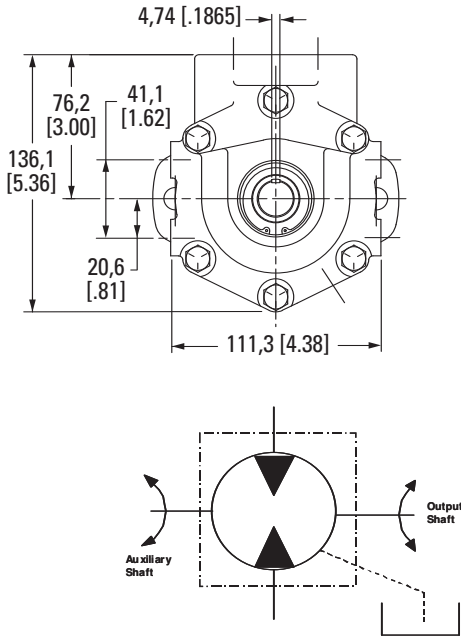

### Output Shafts - Used for all 741XX Models

(Code position 4, 5)

### Spline Shaft Code Selection AA

Maximum Torque on Shaft  
209,3 N•m [1,852 lbf•in]

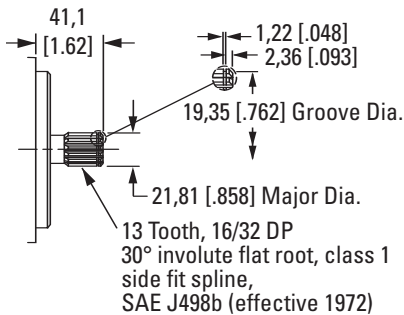

**Note:** All ports are SAE (J1926) o-ring ports. Dimensions are in millimeters [inches], unless otherwise specified.

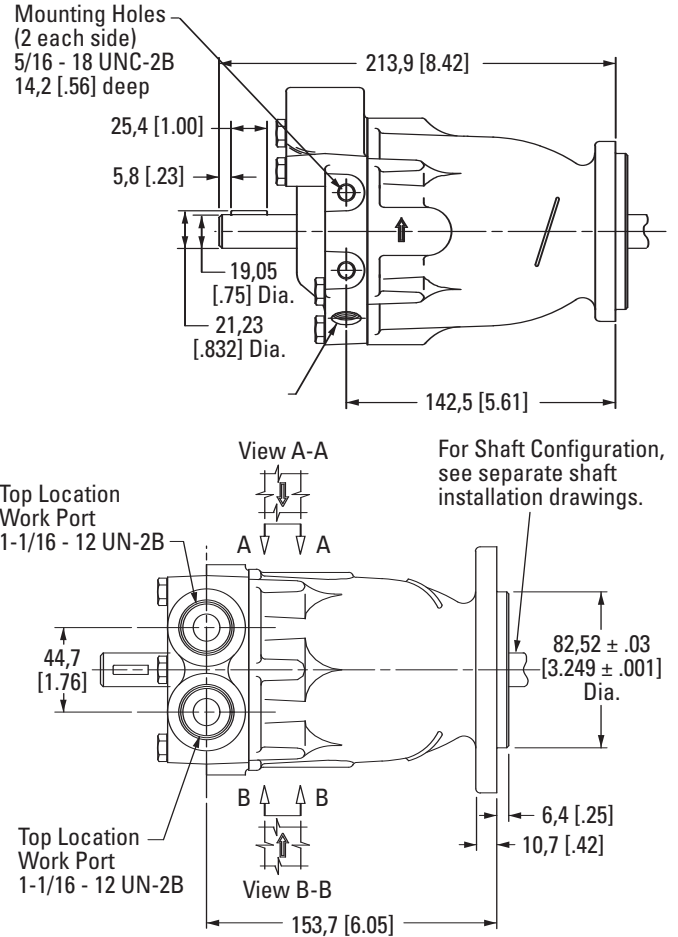

### Keyed Shaft Code Selection AE

Maximum Torque on Shaft  
209,3 N•m [1,852 lbf•in]

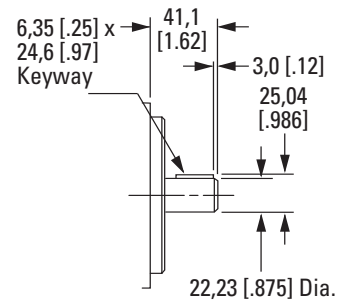

# Fixed Displacement Motor 743XX Model Code

2 Bolt SAE "B" Mount

32,9 cm<sup>3</sup>/r [2.01 in<sup>3</sup>/r]

Displacement

40,6 cm<sup>3</sup>/r [2.48 in<sup>3</sup>/r]

Displacement

49,2 cm<sup>3</sup>/r [3.00 in<sup>3</sup>/r]

Displacement

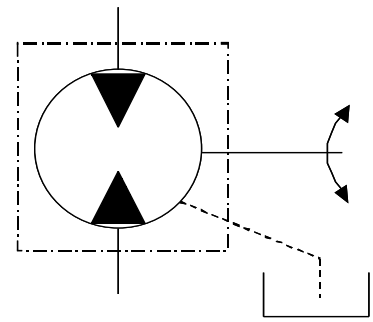

TYPICAL PRODUCT NUMBER	MODEL CODE
74315-DAL	AAJAADBOAAD0A0B
74315-DBB	AAJAADA0AAM0A0B
74315-DBD	AAJABDA0A000A0B
74315-DBG	AAJABDA0AAD0A0B
74315-DBM	AAJABDA0AAM0A0B
74315-DBW	AAJAABA0A000A0B
74318-DAA	AAJAADA00000A0B
74318-DAB	AAJAABA00000A0B
74318-DAC	AAJAACA00000A0B
74318-DAE	AAJAABB00000A0B
74318-DAF	AAJABCG00000A0B
74318-DAG	AAJABBA00000A0B
74318-DBD	AAJABDA00AD0A0B
74318-DBM	AAJABDA00AM0A0B
74318-DBR	AAJABDB00AD0A0B
74318-DBY	AAJABDA00000A0B
74318-DCW	AAJAADA00D0A0B
74318-DDA	AAJABCA00000A0B
74328-DAA	AAKABAJ00000A0B
74328-DAB	AAKAAAB0000000B
74348-DAF	AAJABDA30AD0A0B



SPECIFICATIONS	MODEL 74315	MODEL 74318/74348	MODEL 74328
Maximum Displacement	32,9 cm <sup>3</sup> /r [2.01 in <sup>3</sup> /r]	40,6 cm <sup>3</sup> /r [2.48 in <sup>3</sup> /r]	49,2 cm <sup>3</sup> /r [3.0 in <sup>3</sup> /r]
Maximum Rated Speed	3600 RPM	3600 RPM	3000 RPM
Continuous Rated Pressure †	210 bar [3000 lbf/in <sup>2</sup> ]	210 bar [3000 lbf/in <sup>2</sup> ]	210 bar [3000 lbf/in <sup>2</sup> ]
Maximum Rated Pressure ††	345 bar [5000 lbf/in <sup>2</sup> ]	345 bar [5000 lbf/in <sup>2</sup> ]	328 bar [4750 lbf/in <sup>2</sup> ]
Maximum Intermittent Pressure †††	370 bar [5400 lbf/in <sup>2</sup> ]	370 bar [5400 lbf/in <sup>2</sup> ]	345 bar [5000 lbf/in <sup>2</sup> ]
Input Flow at Rated Speed and Pressure	121 l/min [32 GPM]	153,7 l/min [40.6 GPM]	156,3 l/min [41.3 GPM]
Output Power at Rated Speed and Pressure	35 kW [47 hp]	43 kW [58 hp]	43 kW [58 hp]
Output Torque at Rated Speed and Pressure	92 N•m [816 lbf•in]	115 N•m [1019 lbf•in]	138 N•m [122.5 lbf•in]
Continuous Allowable Case Pressure	1,7 bar [25 lbf/in <sup>2</sup> ]	1,7 bar [25 lbf/in <sup>2</sup> ]	1,7 bar [25 lbf/in <sup>2</sup> ]
Continuous Inlet Temperature	107°C [225°F]	107°C [225°F]	107°C [225°F]
Weight/Single Motor (approximate)	9,1 kg [20 lbs]	9,1 kg [20 lbs]	9,1 kg [20 lbs]

† Continuous Rated Pressure - Motor may run uninterrupted at this pressure.

†† Maximum Rated Pressure - Highest allowable system pressure. (High pressure relief valve setting)

††† Maximum Intermittent Pressure - A pressure spike only for a short period of time, not continuous.

# Model 74315

## Performance Data

The charts below are representative of a 32,9 cm<sup>3</sup>/r [2.01 in<sup>3</sup>/r] displacement piston motor. The tests were run at an oil temperature of 50o C [120oF] with viscosity 19-24 cSt [117-143 SUS].

### Overall Efficiency

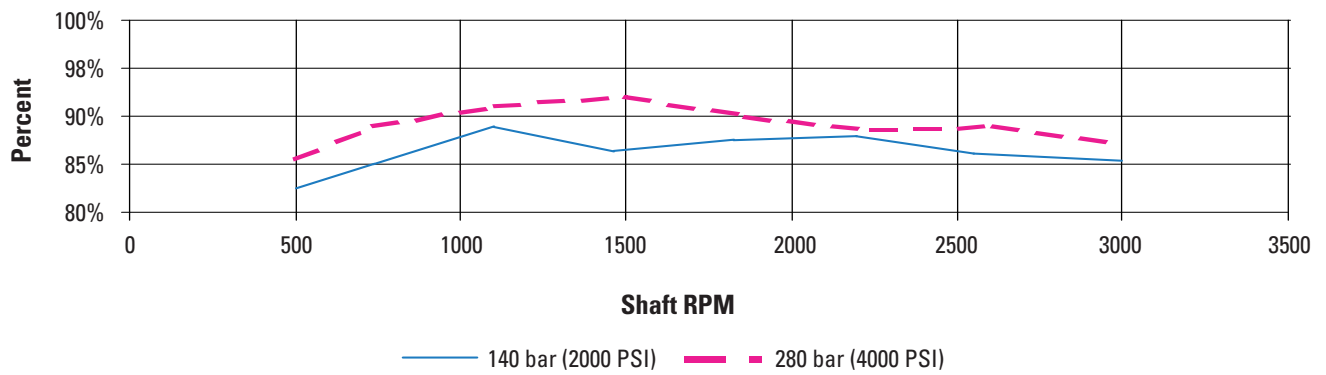

### Volumetric Efficiency

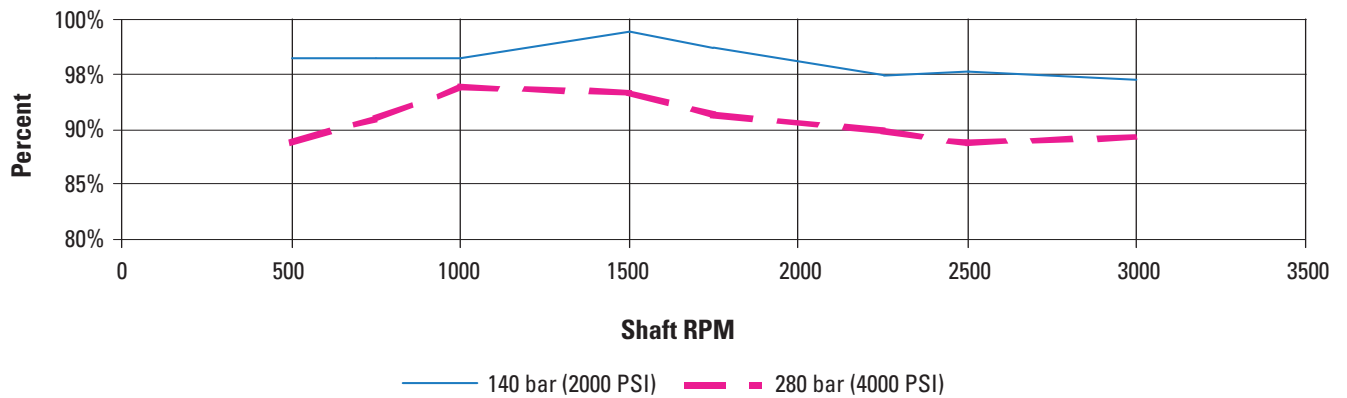

# Model 74315

## Performance Data

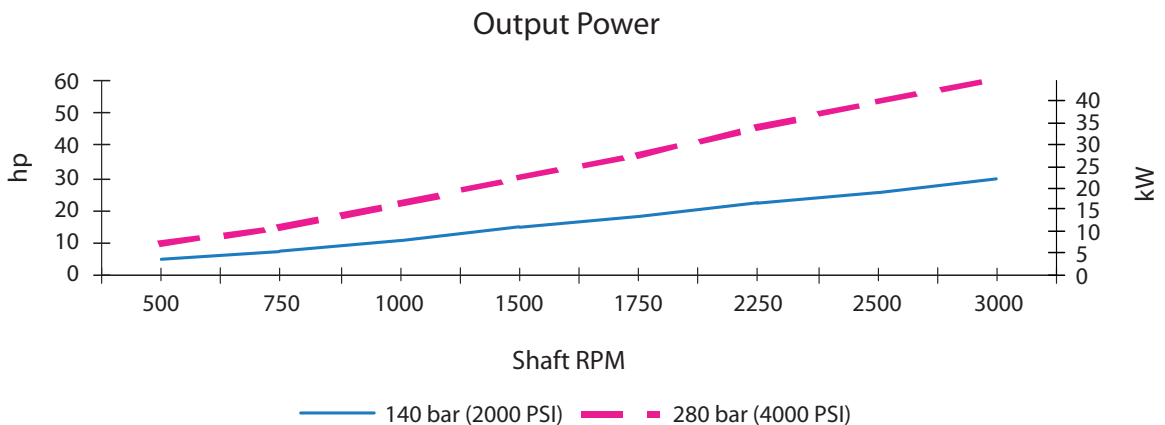
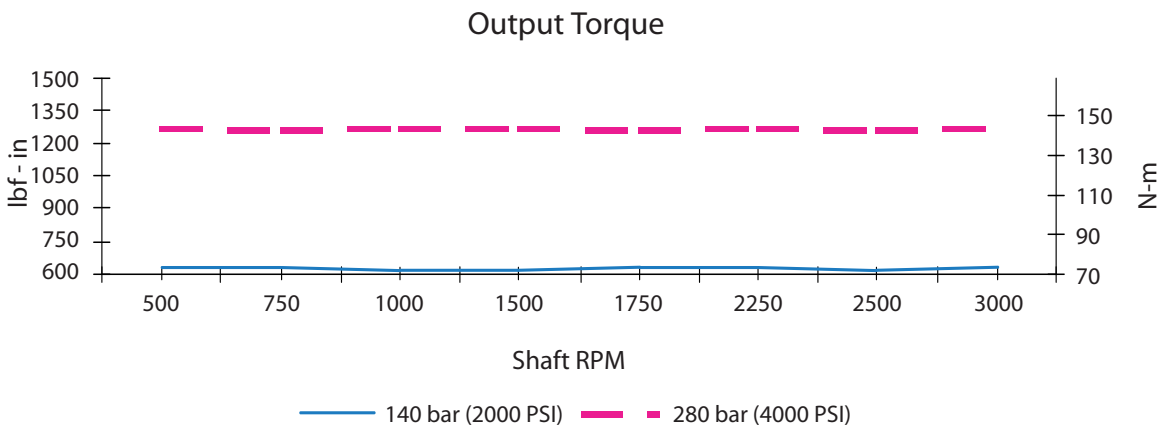
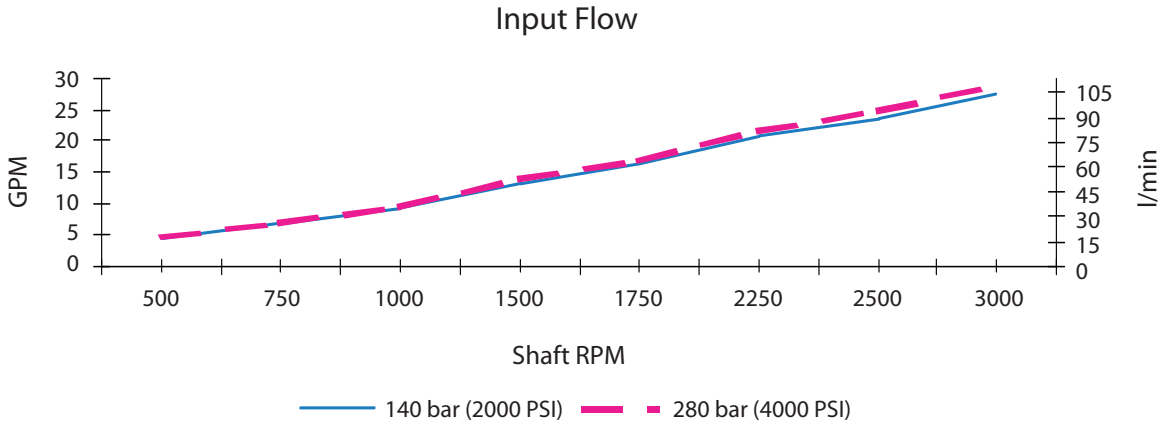

# Model 74318

## Performance Data

The charts below are representative of a 40,6 cm<sup>3</sup>/r [2.48 in<sup>3</sup>/r] displacement piston motor. The tests were run at an oil temperature of 50o C [120oF] with viscosity 19-24 cSt [117-143 SUS].

### Overall Efficiency

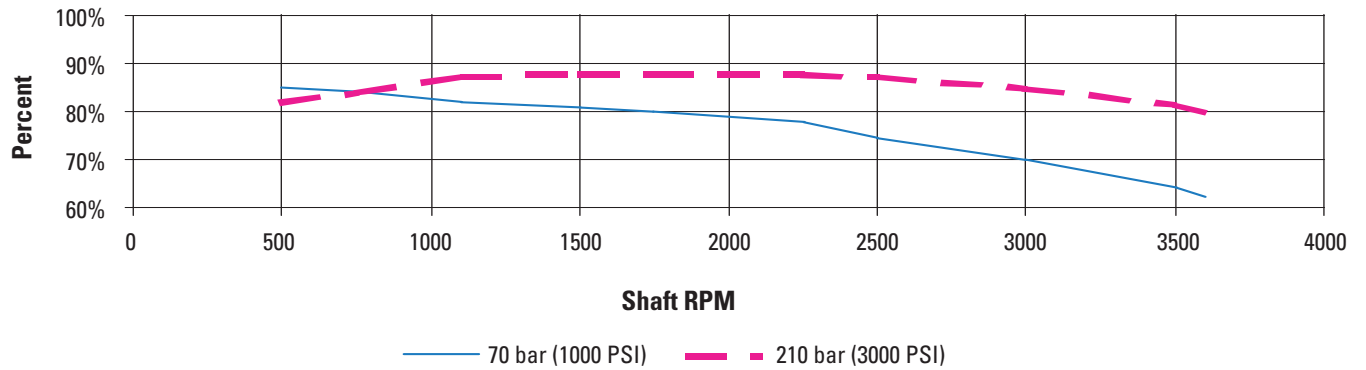

### Volumetric Efficiency

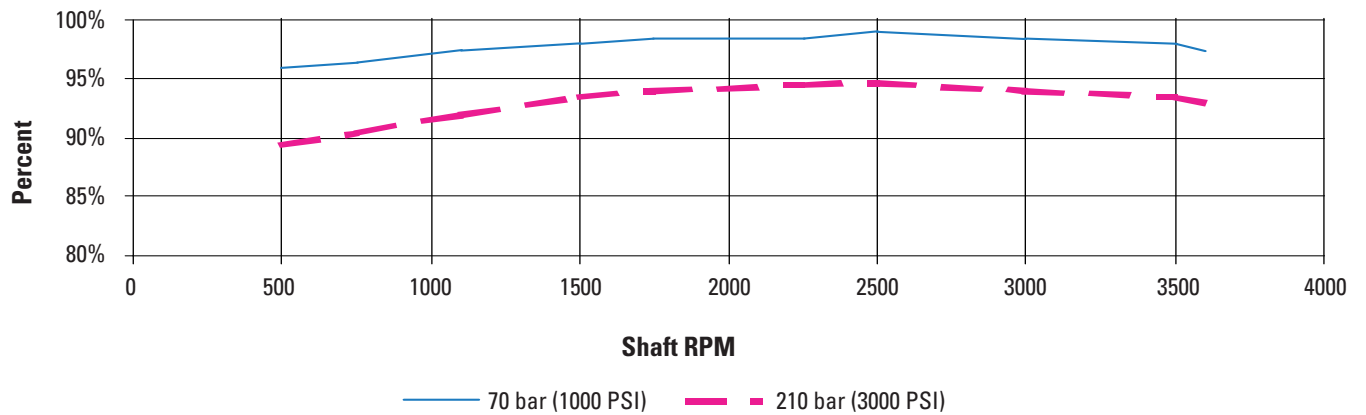

# Model 74318

## Performance Data

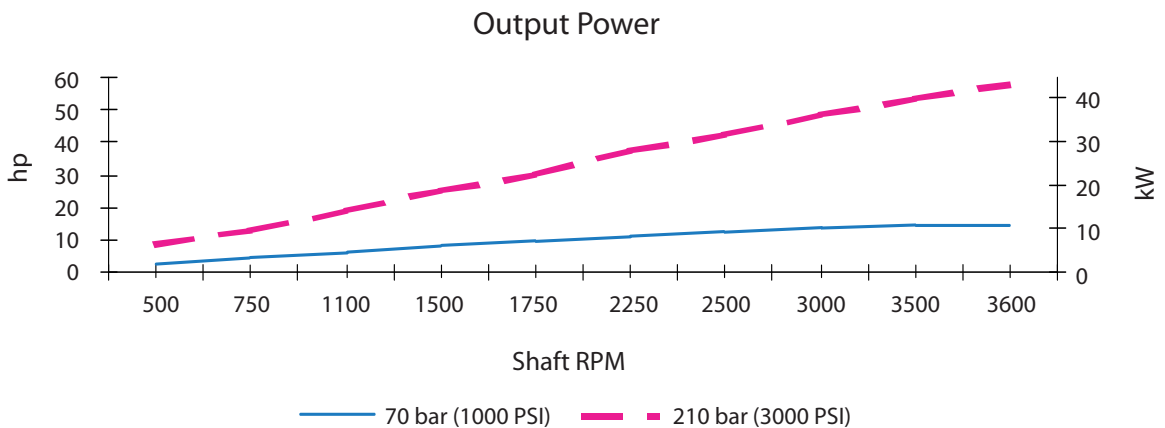
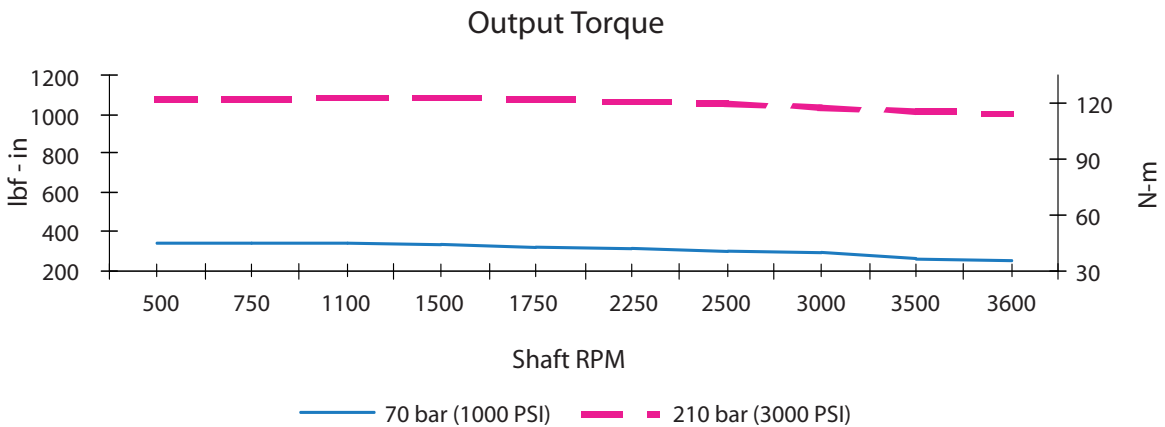
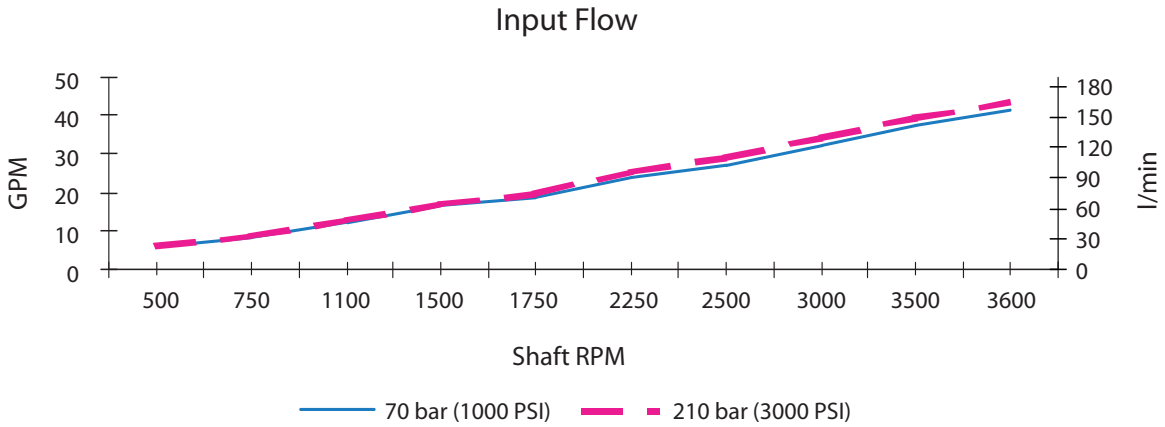

# Model 74328

## Performance Data

The charts below are representative of a 49,2 cm<sup>3</sup>/r [3.00 in<sup>3</sup>/r] displacement piston motor. The tests were run at an oil temperature of 50°C [120°F] with viscosity 19-24 cSt [117-143 SUS].

### Overall Efficiency

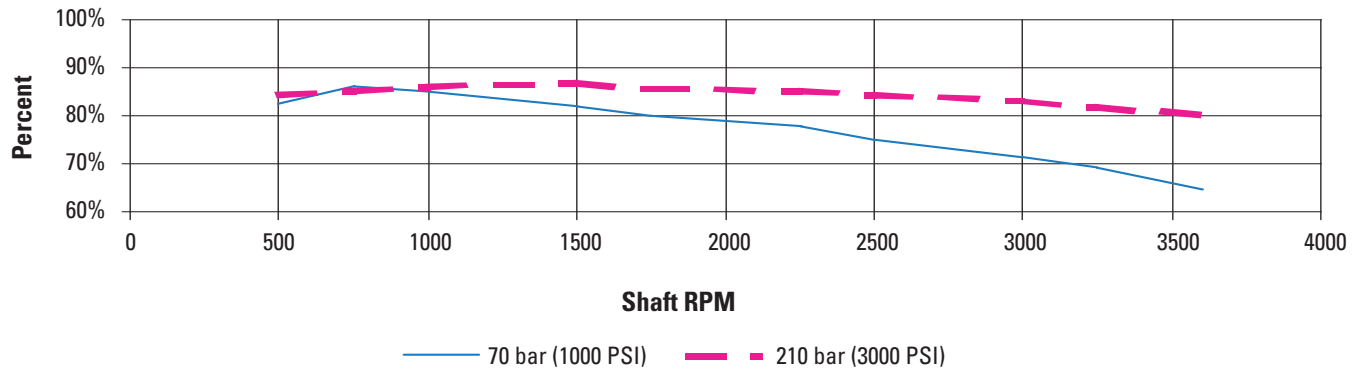

### Volumetric Efficiency

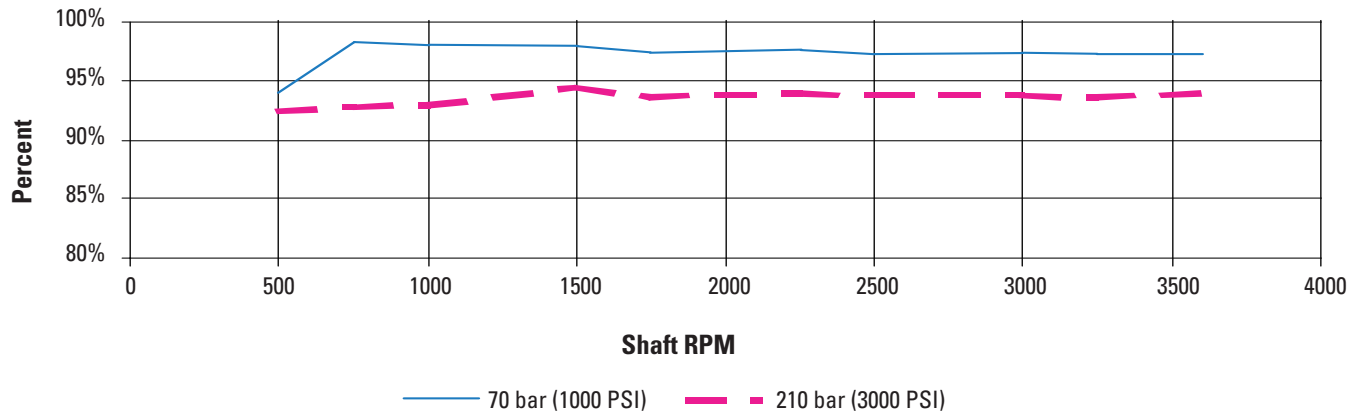



# Model 74328

## Performance Data

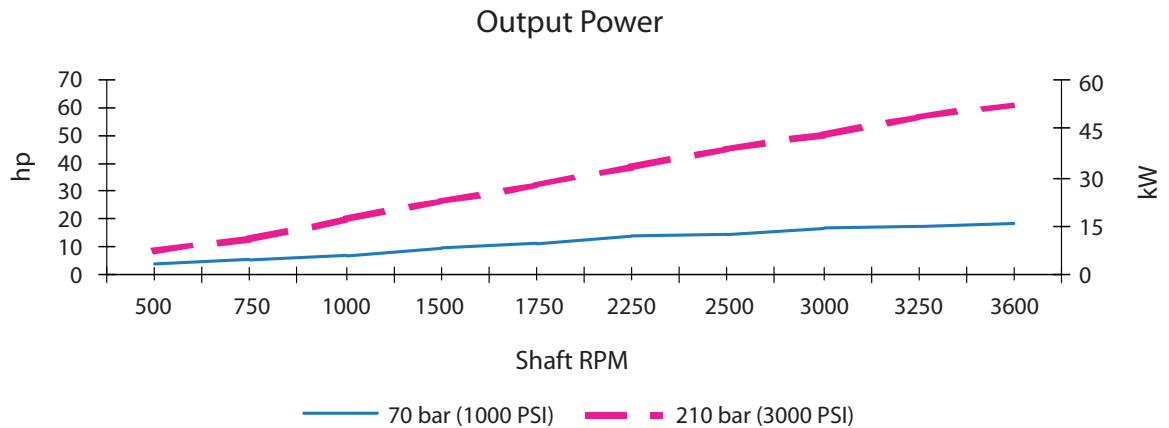
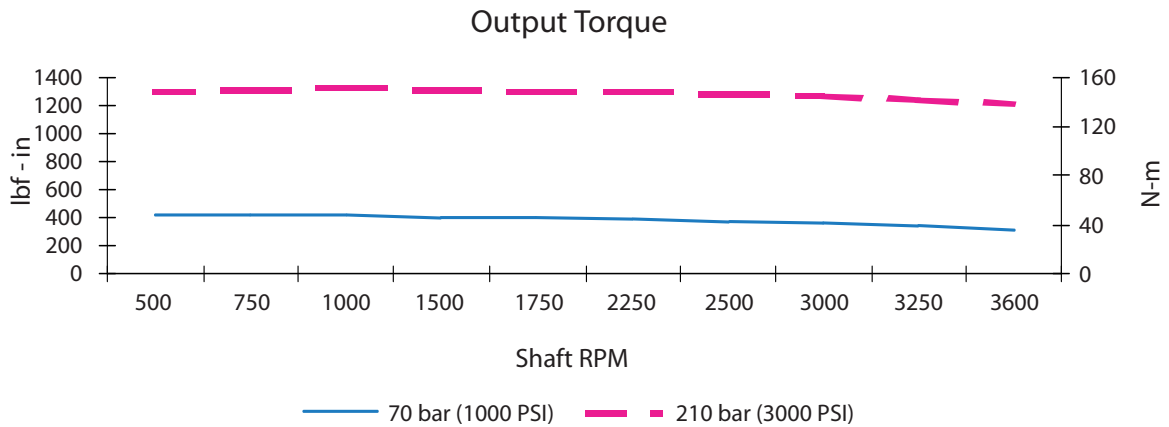
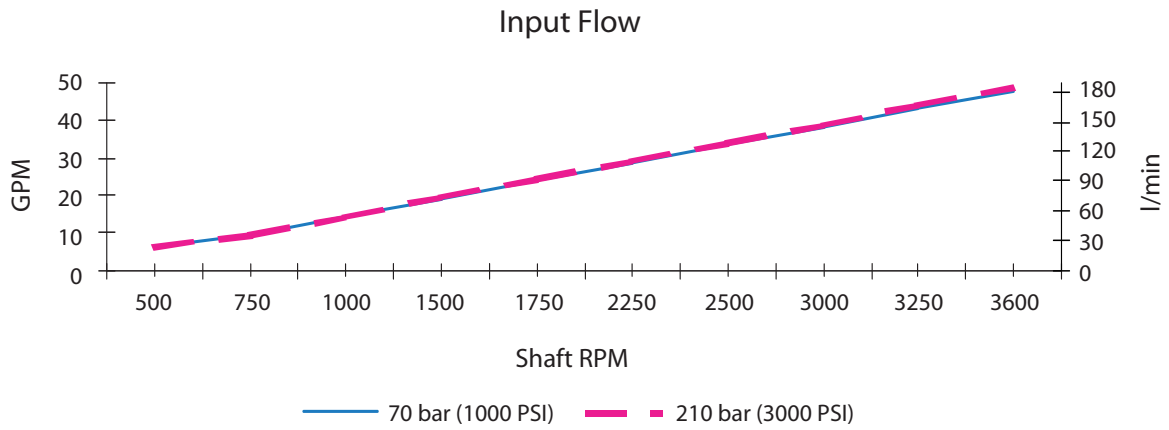

# Fixed Displacement Motor 743XX Model Code

2 Bolt SAE "B" Mount

32,9 cm<sup>3</sup>/r [2.01 in<sup>3</sup>/r]

Displacement

40,6 cm<sup>3</sup>/r [2.48 in<sup>3</sup>/r]

Displacement

49,2 cm<sup>3</sup>/r [3.00 in<sup>3</sup>/r]

Displacement

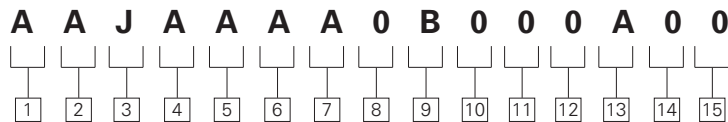

- 1 2 3 Code Title**
- AAJ** - 40,6 cm<sup>3</sup>/r [2.48 in<sup>3</sup>/r]  
Fixed displacement piston motor frame size
  - AAK** - 49,2 cm<sup>3</sup>/r [3.0 in<sup>3</sup>/r]  
Fixed displacement piston motor frame size

- 4 5 Output Shaft**
- AA** - 13 Tooth 16/32 spline shaft extension 41,1 [1.62], (std.)
  - AB** - 15 Tooth 16/32 spline, shaft extension 46 [1.81], (opt.)
  - AD** - Straight Shaft, dia. 28, 58 [1.125], keyway 7,9 [0.31] x 32,5 [1.28], shaft extension 46 [1.81] (key included), (opt.)
  - AE** - Straight Shaft, dia. 22,2 [0.875], keyway 6,3 [0.25] x 24, 6 [0.97], shaft extension 41,1 [1.62] (key included), (std.)

- 6 Main Port, Size, & Location**
- A** - 1-1/16-12-12 UN-2B straight thread o-ring ports- opposite sides, (opt.)
  - B** - 1-5/16-12 UN-2B straight thread o-ring ports- opposite sides, (std.)
  - C** - 1-5/16-12 UN-2B straight thread o-ring ports- rear, (std.)
  - D** - 1-5/16-12 UN-2B straight thread o-ring ports- same side, Top, (opt.)
  - E** - 1-1/16-12 UN-2B straight thread o-ring ports- rear, (opt.)
  - J** - 1-1/16-12 UN-2B straight thread o-ring ports- same side, Top, (opt.)

- 7 Drain Port, Size, & Location**
- A** - 3/4-16 UNF-2B straight thread o-ring port - Top of Housing, (std.)
  - B** - 3/4-16 UNF-2B straight thread o-ring port - Top and bottom of Housing, bottom plugged, (opt.)
  - G** - 3/4-16 UNF-2B straight thread o-ring port - upper rear of Backplate, (opt.)
  - J** - 9/16-18 UNF-2B straight thread o-ring port-upper rear of Backplate, (opt.)

- 8 Auxiliary Mounting Features (rear)**
- 0** - No Auxiliary Mounting Feature (std.)
  - 1\*** - Straight through shaft, dia. 22,23 [0.875], with keyway 4,75 x 26,9 [0.187 x 1.06] (key included, 19 [0.75] long). Side Mounting Pad holes both sides, 4 x .3125-18.  
*Note: Requires the selection in position 6 of same side porting. (opt.)*

- 9 Displacement Options**
- 0** - As given in code title, 40,6 cm<sup>3</sup>/r [2.48 in<sup>3</sup>/r] - Model 74318 or 74348, (std.)
  - A** - 32,9 cm<sup>3</sup>/r [2.01 in<sup>3</sup>/r] destroked from 40,6 cm<sup>3</sup>/r [2.48 in<sup>3</sup>/r] - Model 74315, (opt.)

- B** - 24 cm<sup>3</sup>/r [1.50 in<sup>3</sup>/r] destroked from 40, 6 cm<sup>3</sup>/r [2.48], (opt.)

- 10 11 Special Features**
- 00** - No special feature, (std.)
  - AD** - Shuttle Valve and Charge Pressure Valve set at 15-17 bar [220-250 lbf/in<sup>2</sup>], (opt.)
  - AM** - Shuttle Valve and Charge Pressure Valve set at 10-12 bar [150-175 lbf/in<sup>2</sup>], (opt.)
  - AP** - Speed Sensor Hall Effect Pickup (9 pulse), lead wire 127mm [5.0in] long,(opt.)
  - CA** - Speed Sensor, Hall Effect Pickup (9 pulse) with M12 connector (opt.)

- 12 13 Paint**
- 0A** - Primer, (std.)
  - 0B** - Black Paint, (std.)

- 14 Identification**
- 0** - Standard, (std.)

- 15 Design Code**
- 0** - Eaton assigns current design code, (std.)

**Fixed displacement piston motors are specified by the following model code. Once a motor is built from the model code, a product number will be assigned to that configuration. Make sure all positions are selected within the 15 digit code for each motor.**

# Model 74315, 74318 and 74328

## Installation Drawings

### Output Shafts - Used for all 743XX Models

(Code position 4,5)

#### Spline Shaft Code Selection AA

Maximum Torque on Shaft  
209,3 N•m [1,852 lbf•in]

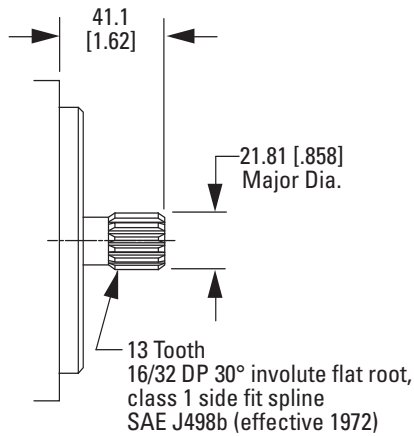

#### Spline Shaft Code Selection AB

Maximum Torque on Shaft  
337,5 N•m [2,987 lbf•in]

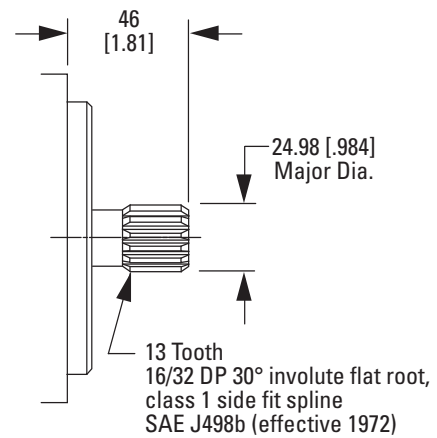

#### Spline Shaft Code Selection AD

Maximum Torque on Shaft  
337,5 N•m [2,987 lbf•in]

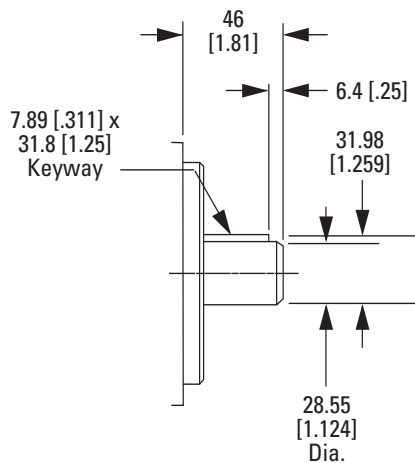

#### Spline Shaft Code Selection AE

Maximum Torque on Shaft  
209,3 N•m [1,852 lbf•in]

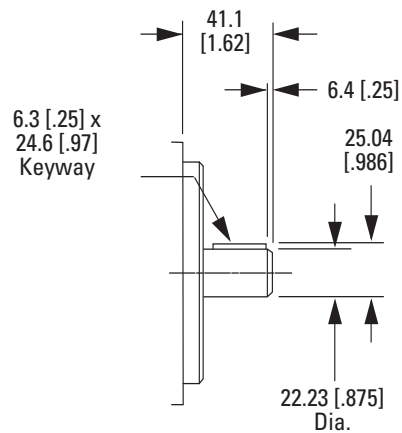

**Note: All ports are SAE (J1926) o-ring ports. Dimensions are in millimeters [inches], unless otherwise specified.**

# Model 74315, 74318 and 74328

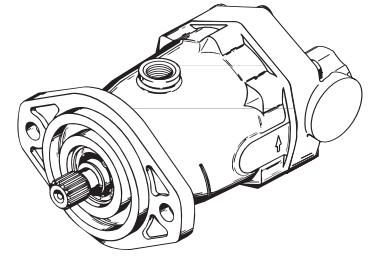

## Installation Drawings

### Opposite Side Porting

(Code position 6, selection A or B)

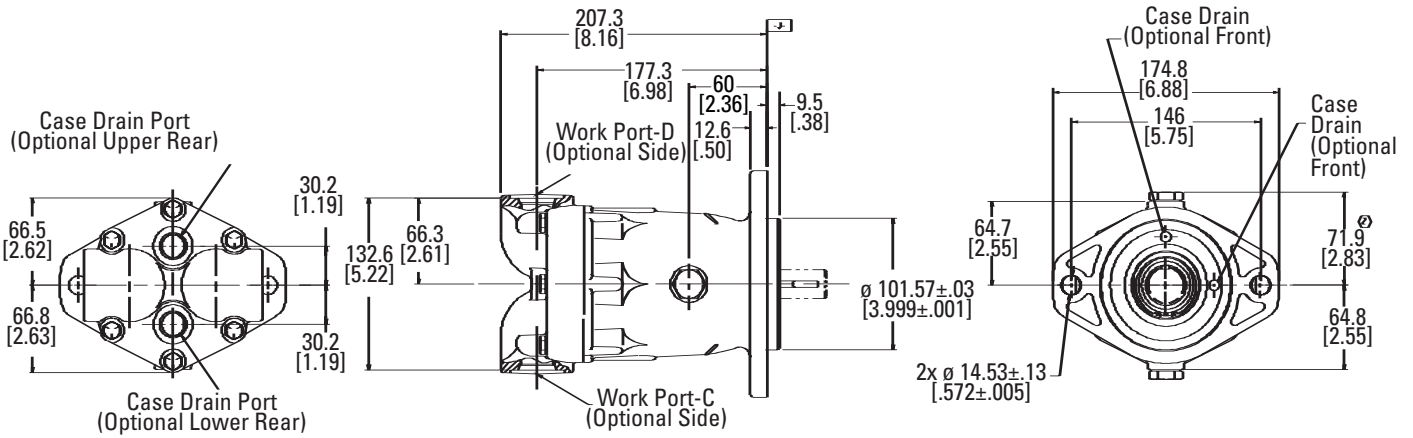

### Rear Porting

(Code position 6, selection C or D)

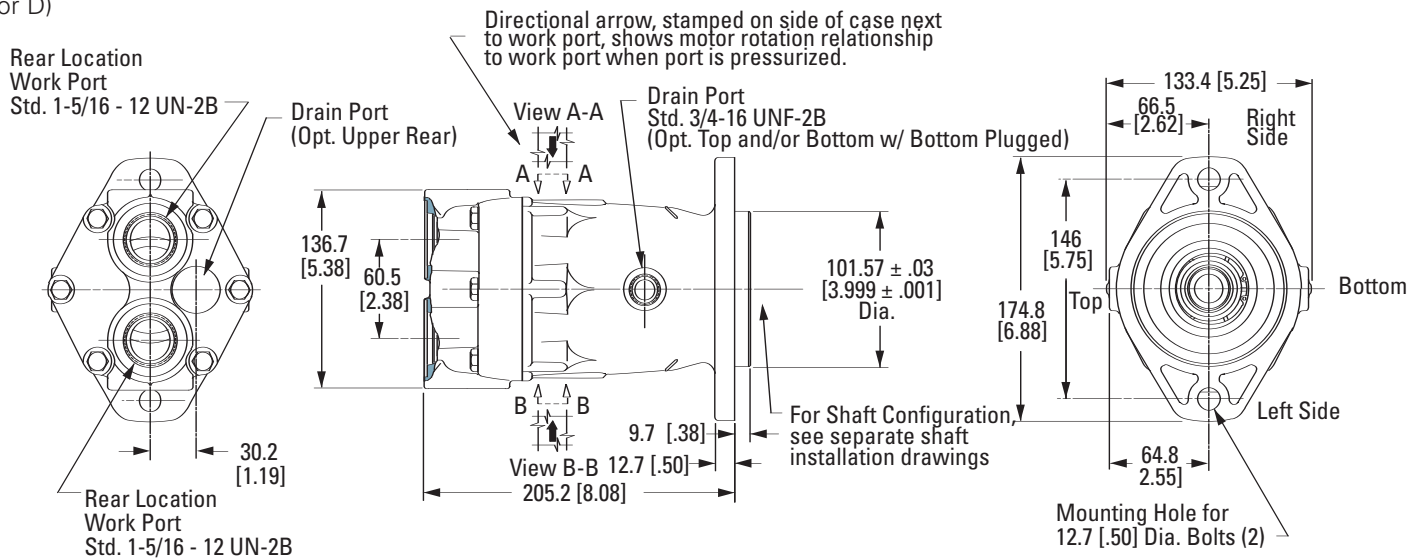

**Note:** All ports are SAE (J1926) o-ring ports. Dimensions are in millimeters [inches], unless otherwise specified.

# Model 74315, 74318 and 74328

## Installation Drawings

### Same Side Porting

(Code position 6, selection D)

Directional arrow, stamped on side of case next to work port, shows motor rotation relationship to work port when port is pressurized.

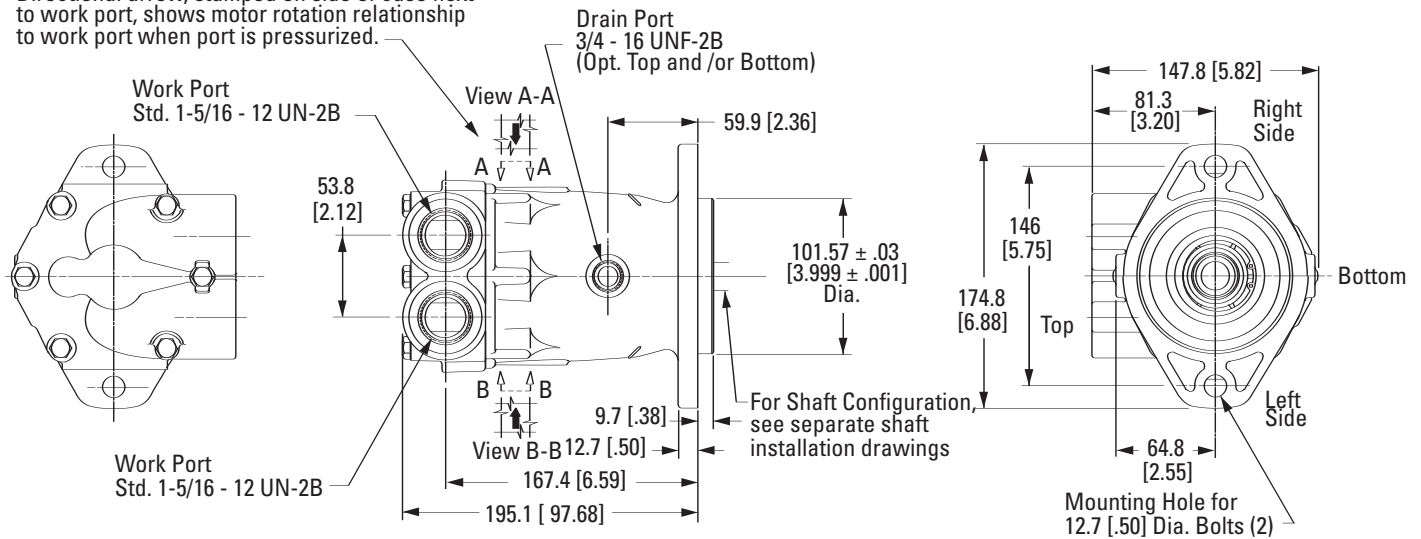

**Note: All ports are SAE (J1926) o-ring ports. Dimensions are in millimeters [inches], unless otherwise specified.**

# Model 74315, 74318 and 74328

## Installation Drawings

### Same Side Porting w/ Shuttle Valve and Charge Pressure Valve

(Code position 10, 11 selection AD or AM)

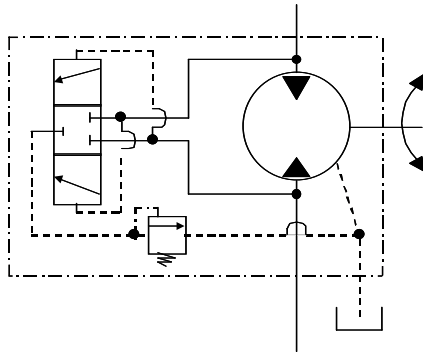
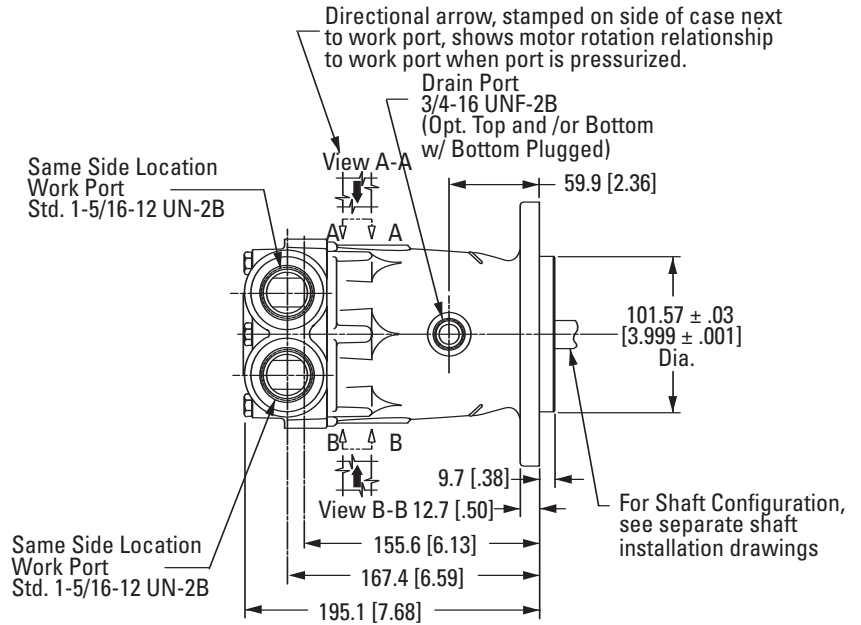
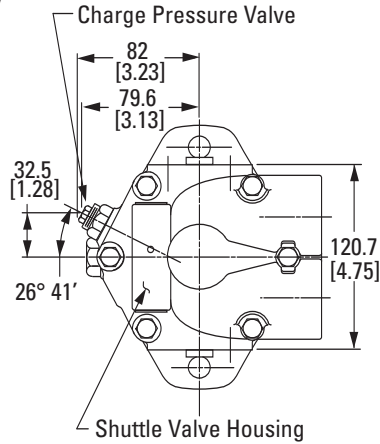

The shuttle and charge pressure valve work together to bypass closed loop oil. This allows the oil to be cooled, filtered, and returned to tank.

The shuttle valve flow is listed below in relationship to the charge pressure valve setting.

CHARGE PRESSURE	FLOW	CODE SELECTION
10 to 12 bar [145 to 175 lbf/in <sup>2</sup> ]	5,68 to 9,46 l/m [1.5 to 2.5 gal/min]	AM
15 to 17 bar [220 to 250 lbf/in <sup>2</sup> ]	9,46 to 13,25 l/m [2.5 to 3.5 gal/min]	AD

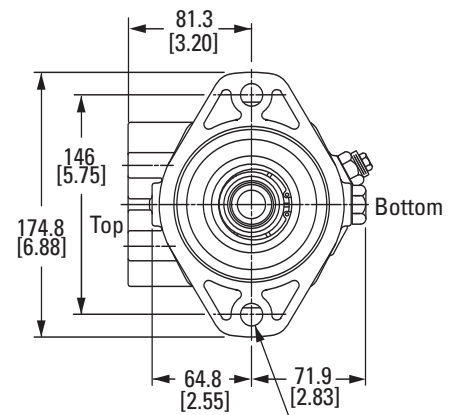

Mounting hole for  
12.7 [0.50] Dia. Bolts (2)

**Note:** All ports are SAE (J1926) o-ring ports. Dimensions are in millimeters [inches], unless otherwise specified.

# Model 74348

## Installation Drawings

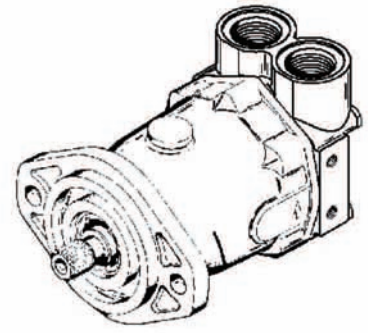

### Same Side Porting w/ Through shaft for brake mounting

(Code position 6, selection D)  
(Code position 8, selection 3)

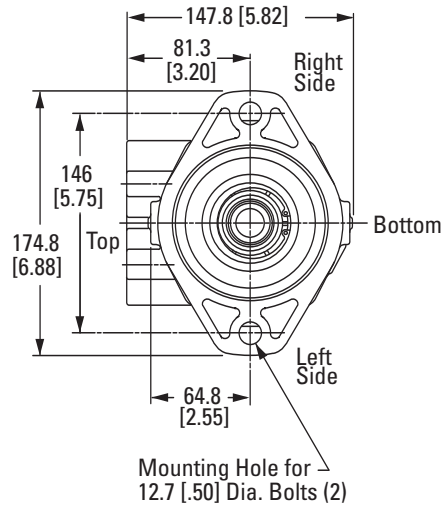
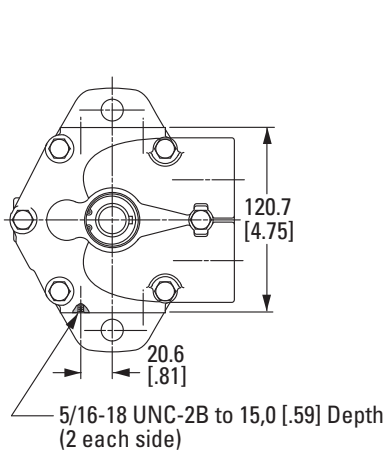
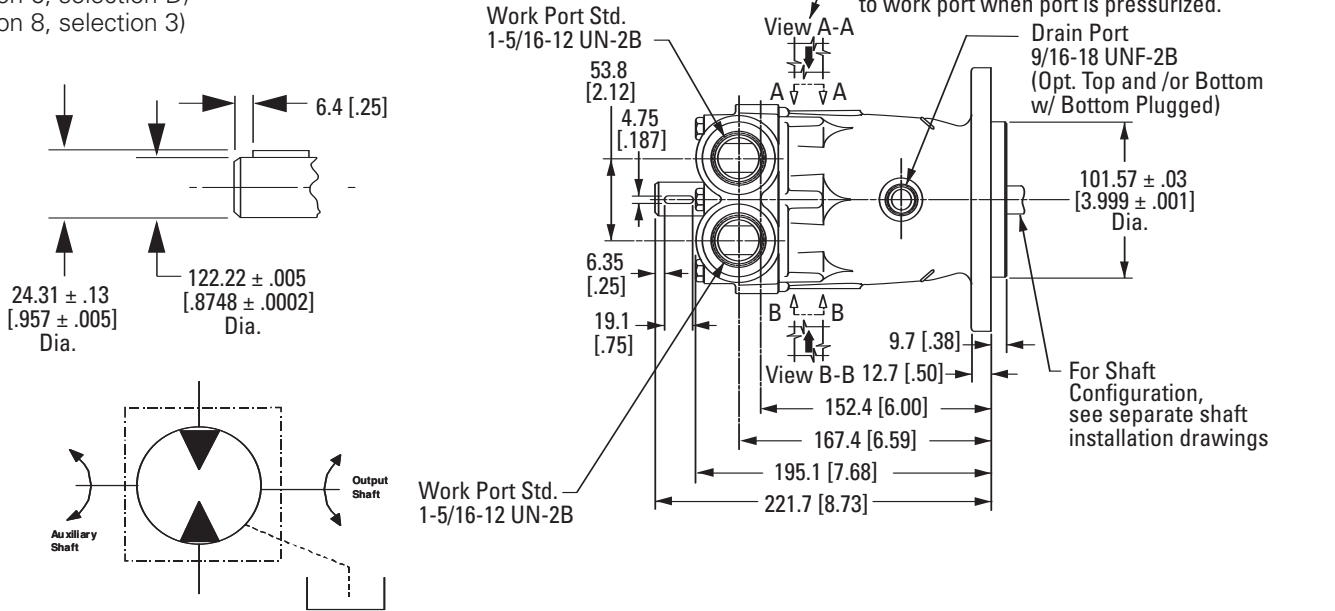

**Note: All ports are SAE (J1926) o-ring ports. Dimensions are in millimeters [inches], unless otherwise specified.**

# Model 743XX

## Installation Drawings

### Motor Speed Sensor

(Code position 10, 11 selection AP)

The Hall Effect speed sensor is compatible with the mobile vehicle electrical systems and gives a reliable digital on/off signal over a wide speed and temperature range.

The rugged design is fully protected against reverse polarity or short circuit hook up. A built-in pull up resistor simplifies installation with control systems.

The motor speed sensor is a factory installed option.

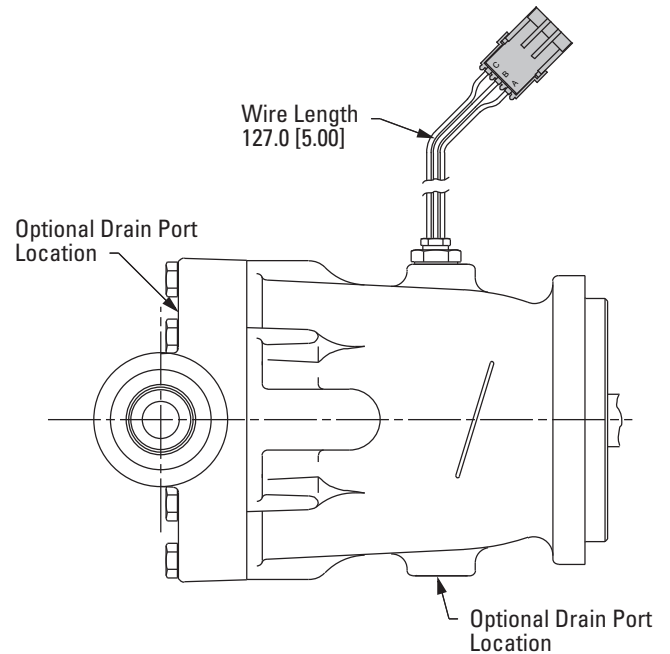
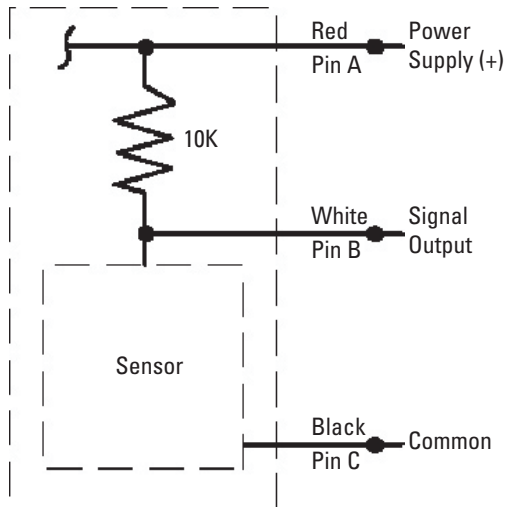

#### SPECIFICATION

Supply Voltage:	(Vs) 12 Volt DC (Nominal Vehicle Power)
Supply Current:	(Is) 20 mA (including internal pull up resistor)
Output Voltage High:	Supply Voltage minus 0.5 Volt DC min. (Open Collector with 10k pull up resistor)
Output Voltage Low:	(Vol) 0.5 Volt DC Maximum at 10 mA
Min. Shaft RPM:	50
Pulses per Revolution:	9

#### CONNECTION REQUIREMENTS

Cable: 18 AWG Recommended wire .100 nominal O.D. for proper seal, 1 black, 1 red, 1 white.

Packard Electric Weather Pack Series: Mating female assembly #12015793 connector and #12089188 terminal (3).

**Note:** All ports are SAE (J1926) o-ring ports. Dimensions are in millimeters [inches], unless otherwise specified.



# Model 743XX

## Installation Drawings

### Motor Speed Sensor - M12

(Code position 10, 11 selection CA)

Eaton has developed a speed sensor, based on the field proven technology of our Hall Effect and Magnetic sensor.

Output – Digital signals from NPN transistors (open collector output with internal 10K pull up resistors).

This sensor has reverse polarity protection, short circuit protection, load dump protection, and EMC (Electrical Magnetic Capability) protection (the customer should qualify the EMC protection in their specific application)

Supply Voltage: 8 to 24 Volt DC (compatible with 12V vehicle conditions)

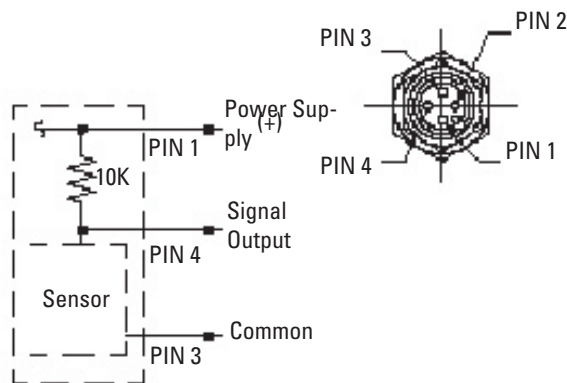
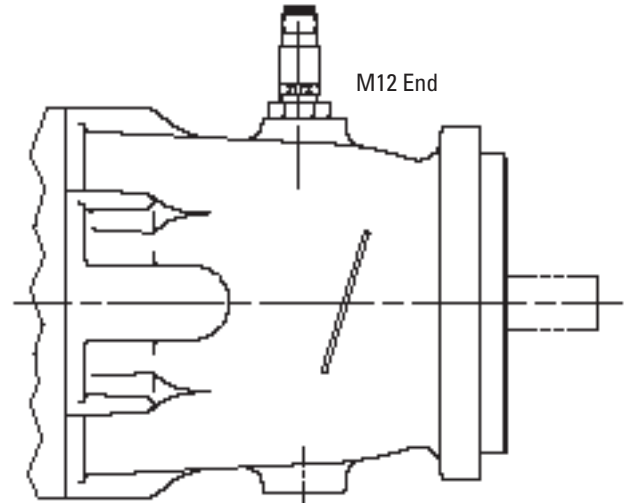

Output circuit wiring instructions

#### SPECIFICATION

Supply Voltage:	(Vs) 12 Volt DC (Nominal Vehicle Power 8 to 24 V DC)
Supply Current:	(Is) 20 mA (including internal pull up resistor)
Output Voltage High:	(Open Collector with 10k pull up resistor)
Output Voltage Low:	(Vol) 0.5 Volt DC Maximum at 10 mA
Min. Shaft RPM:	50
Pulses per Revolution:	9

#### CONNECTION REQUIREMENTS

Mates with DC Micro connectors or equivalent: Turk Eurofast WKCV 4T cable  
 Brad Harrison Micro-Change single keyway plugs  
 Lumberg Micro style 12mm DC connector

**Note: All ports are SAE (J1926) o-ring ports. Dimensions are in millimeters [inches], unless otherwise specified.**

# Fixed Displacement Motor 746XX Models

2 Bolt SAE "B-B" Mount  
82,6 cm<sup>3</sup>/r [5.04 in<sup>3</sup>/r]  
Displacement

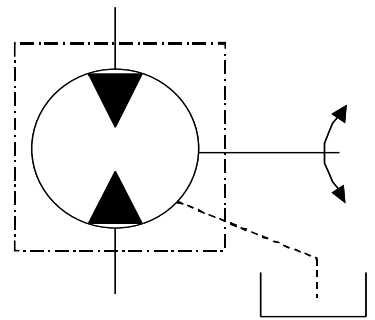

TYPICAL PRODUCT NUMBER	MODEL CODE
74624-DAH	AAZAAAA0000A0B
74624-DAV	AAZAABB0000A0B
74644-DAJ	AAZAABBA000A0B
74624-DAB	AAZADAA0000A0B
74644-DAJ	AAZAABBA000A0B



SPECIFICATIONS	MODEL 74624/74644
Maximum Displacement	82,6 cm <sup>3</sup> /r [5.04 in <sup>3</sup> /r]
Maximum Rated Speed	1500 RPM
Continuous Rated Pressure †	240 bar [3500 lbf/in <sup>2</sup> ]
Maximum Rated Pressure ††	240 bar [3500 lbf/in <sup>2</sup> ]
Maximum Intermittent Pressure †††	265 bar [3900 lbf/in <sup>2</sup> ]
Input Flow at Rated Speed and Pressure	129 l/min [34 GPM]
Output Power at Rated Speed and Pressure	43,3 kW [58.0 hp]
Output Torque at Rated Speed and Pressure	280,3 N•m [2481 lbf•in]
Continuous Allowable Case Pressure	7 bar [100 lbf/in <sup>2</sup> ]
Continuous Inlet Temperature	107°C [225°F]
Weight/Single Motor (approximate)	10,9 kg [24 lbs]

† Continuous Rated Pressure - Motor may run uninterrupted at this pressure.  
 †† Maximum Rated Pressure - Highest allowable system pressure. (High pressure relief valve setting)  
 ††† Maximum Intermittent Pressure - A pressure spike only for a short period of time, not continuous.

## Performance Data

The charts below are representative of a 82,6 cm<sup>3</sup>/r [5.04 in<sup>3</sup>/r] displacement piston motor. The tests were run at an oil temperature of 80o C [180oF] with viscosity 7-9 cSt [50-54 SUS].

### Overall Efficiency

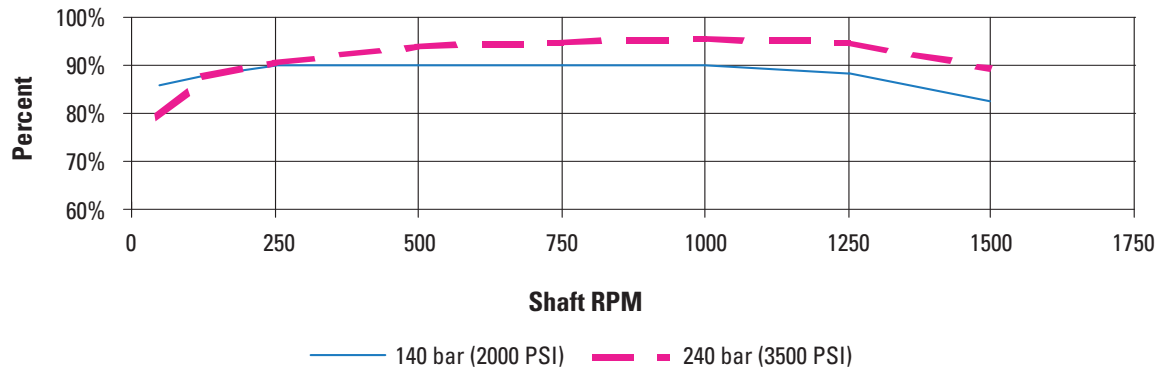

### Volumetric Efficiency

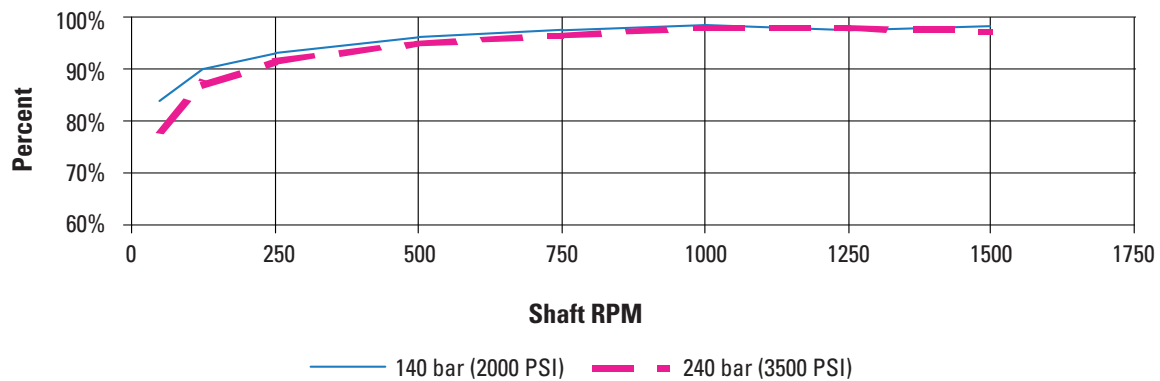

# Model 74624

## Performance Data

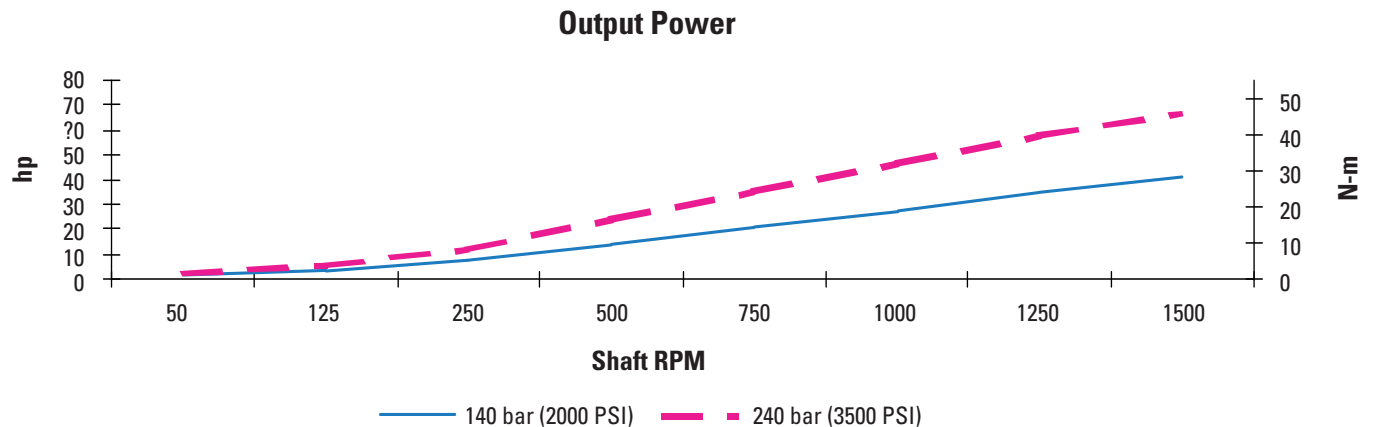
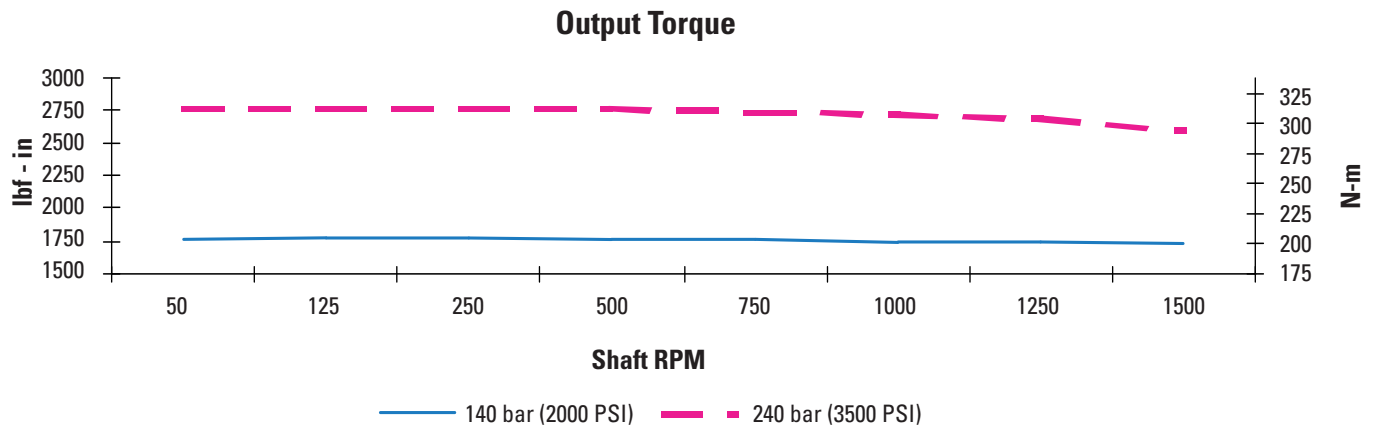
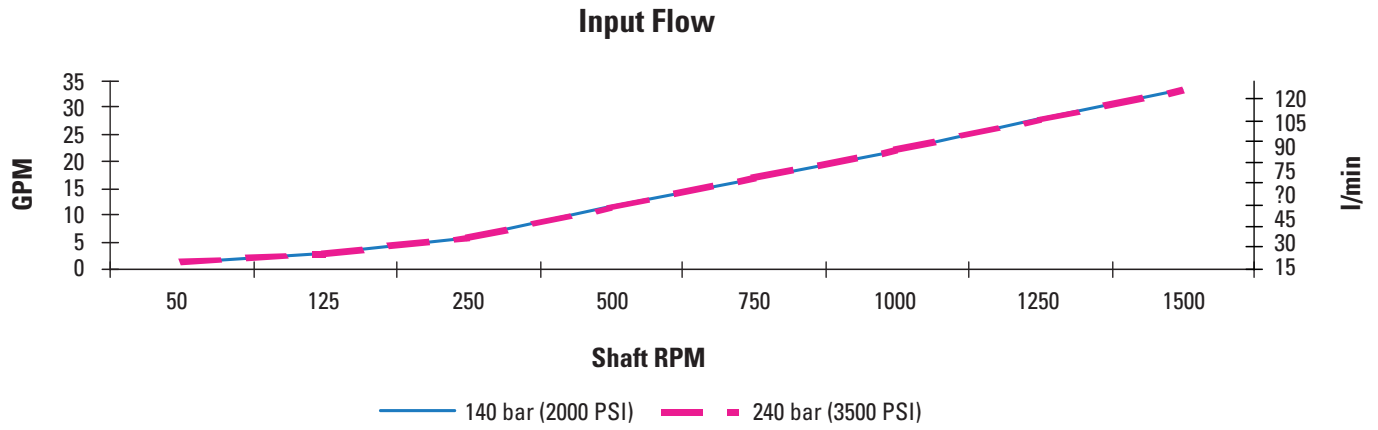

# Fixed Displacement Motor 746XX Models

82,6 cm<sup>3</sup>/r [5.04 in<sup>3</sup>/r]  
Displacement

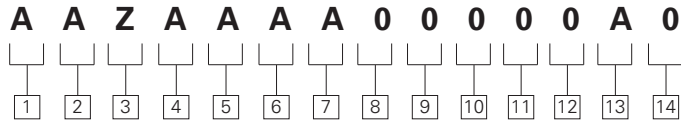

## **1 2 3** Code Title

**AAZ** - 82, 6 cm<sup>3</sup>/r [5.04 in<sup>3</sup>/r]  
High Torque Fixed displacement piston motor frame size

## **4 5** Output Shaft

- AA** - Straight Shaft, dia. 25,4 [1.00], keyway 6,30 [.248] x 37,3 [1.47], shaft extension 63,5 [2.50] (key included), (std.)
- AD** - 15 Tooth 16/32 spline with snap ring groove, shaft extension 46 [1.81], (std.)

## **6** Main Port, Size, & Location

- A** - 1-1/16-12 UN-2B straight thread o-ring ports- rear, (std.)
- B** - 1-1/16 UN-2B straight thread o-ring ports- same side, top, (opt.)

## **7** Drain Port, Size, & Location

- A** - 9/16-18 UNF-2B straight thread o-ring port - Horizontal top rear of unit, (std.)
- B** - 9/19-18 UNF-2B straight thread o-ring port - Vertical top rear of unit, (opt.)

## **8** Auxiliary Mounting Features (rear)

- 0** - No Auxiliary Mounting Feature - Model 74624, (std.)
- A\*** - Straight through shaft, dia. 25,4 [1.00], with keyway 6,35 x 25,4 [.250 x 1.00], Shaft length from mounting flange 274,3 [10.80] (key included); 2 mounting holes 5/16-18 UNC-2B Thd, 13,3 [.53] min. full thread (bottom rear of unit) - Model 74644, (opt.)
- C\*** - 15 Tooth 16/32 spline, shaft length from mounting flange 258,6 [10.18]; 2 mounting holes 5/16-18 UNC-2B Thd, 13,3 [.53] min. full Thd (bottom rear of unit) - Model 74644, (opt.)

## **9 10** Special Features

- 00** - No Special Features, (std.)

## **11 12** Paint

- 0A** - Primer, (std.)
- 0B** - Black Paint, (std.)

## **13** Identification

- 0** - Standard, (std.)

## **14** Design Code

- 0** - Eaton assigns current design code, (std.)

*\* Requires the selection of same side porting only.*

*Note: All ports are SAE (J1926) o-ring ports.*

**High torque fixed displacement piston motors are specified by the following model code. Once a motor is built from the model code, a product number will be assigned to that configuration. Make sure all positions are selected within the 14 digit code for each motor.**

# Model 74624 and 74644

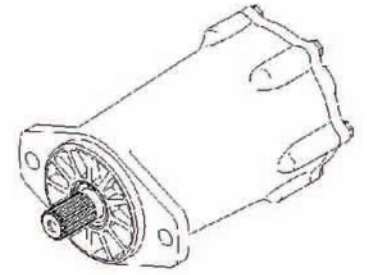

## Installation Drawings

### Rear Porting

(Code position 6, selection A)

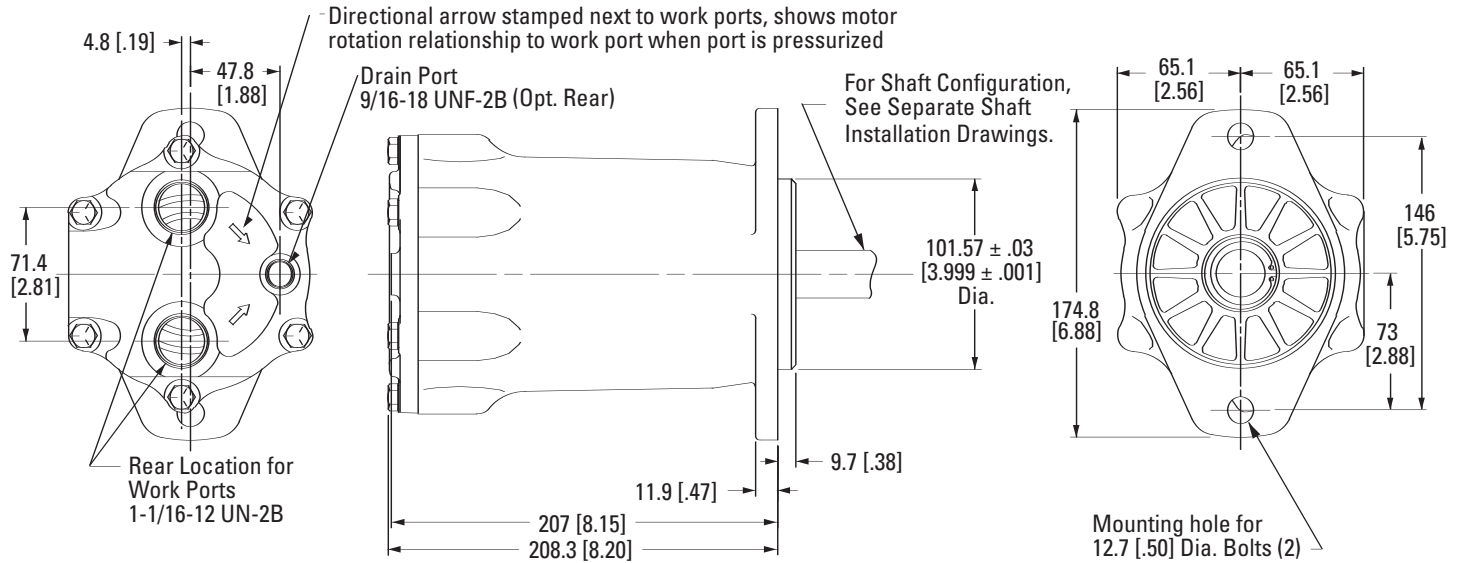

### Output Shafts used for all 746XX models

(Code position 4, 5 selection AA or AD)

#### Spline Shaft

(Code selection AA)

Maximum Torque on Shaft  
Shaft AA - 337,5 N•m [2987 lbf•in]

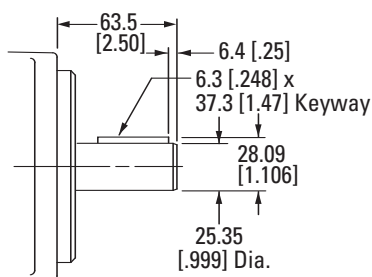

#### Spline Shaft

(Code selection AD)

Maximum Torque on Shaft  
Shaft AA - 337,5 N•m [2987 lbf•in]

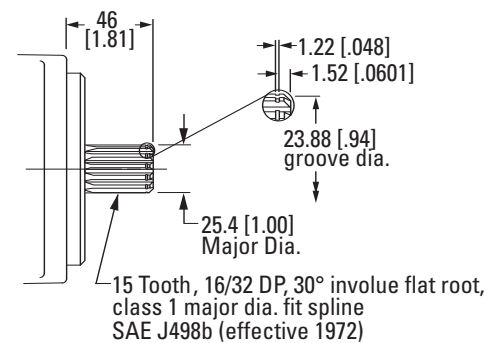

**Note:** All ports are SAE (J1926) o-ring ports. Dimensions are in millimeters [inches], unless otherwise specified.

# Model 74624

## Installation Drawings

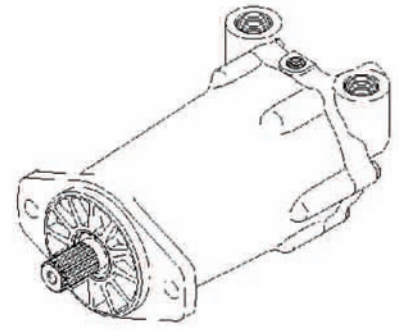

### Same Side Porting

(Code position 6, selection B)

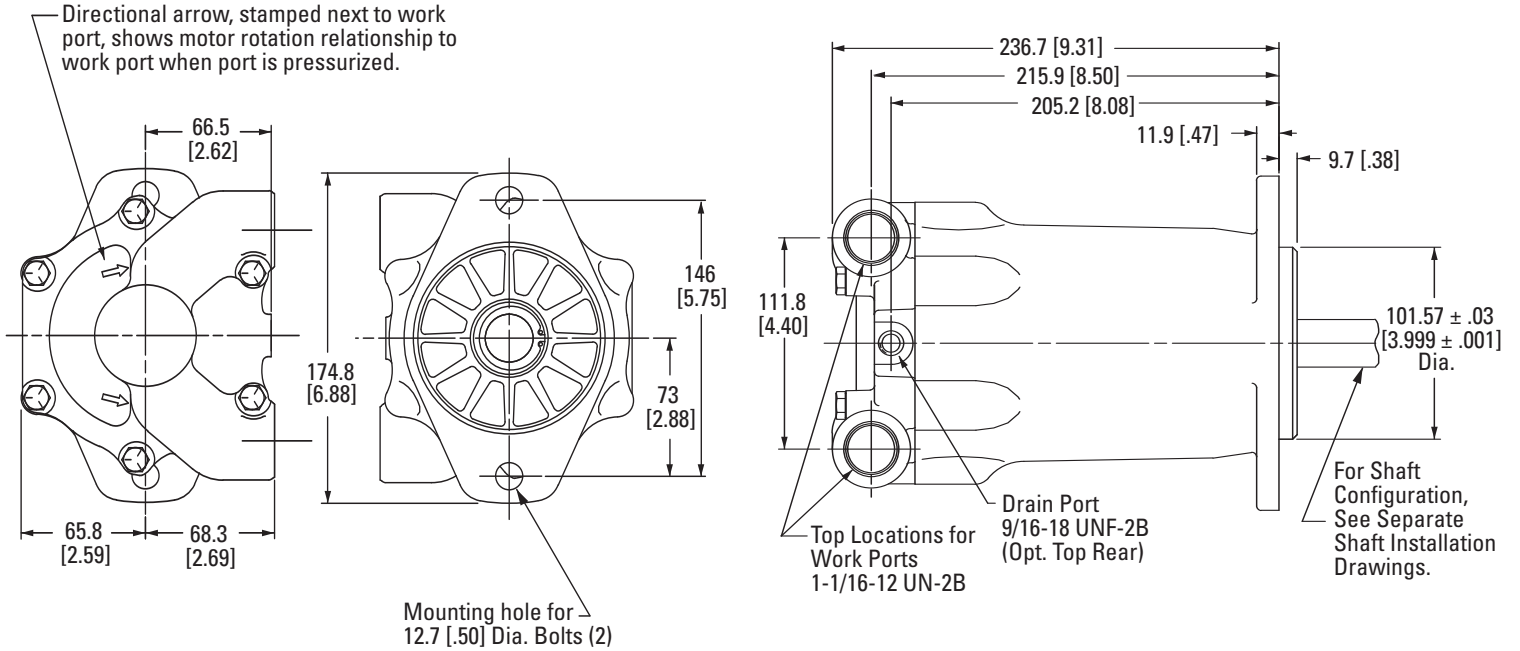

**Note:** All ports are SAE (J1926) o-ring ports. Dimensions are in millimeters [inches], unless otherwise specified.

# Model 74644

## Installation Drawings

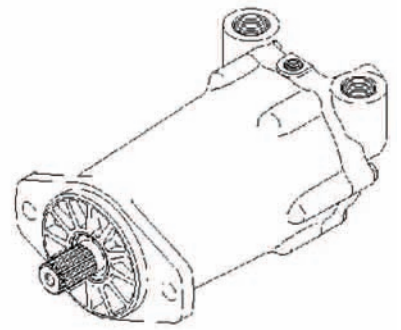

### Through Shaft for Brake Mounting

(Code position 8, selection A or C)

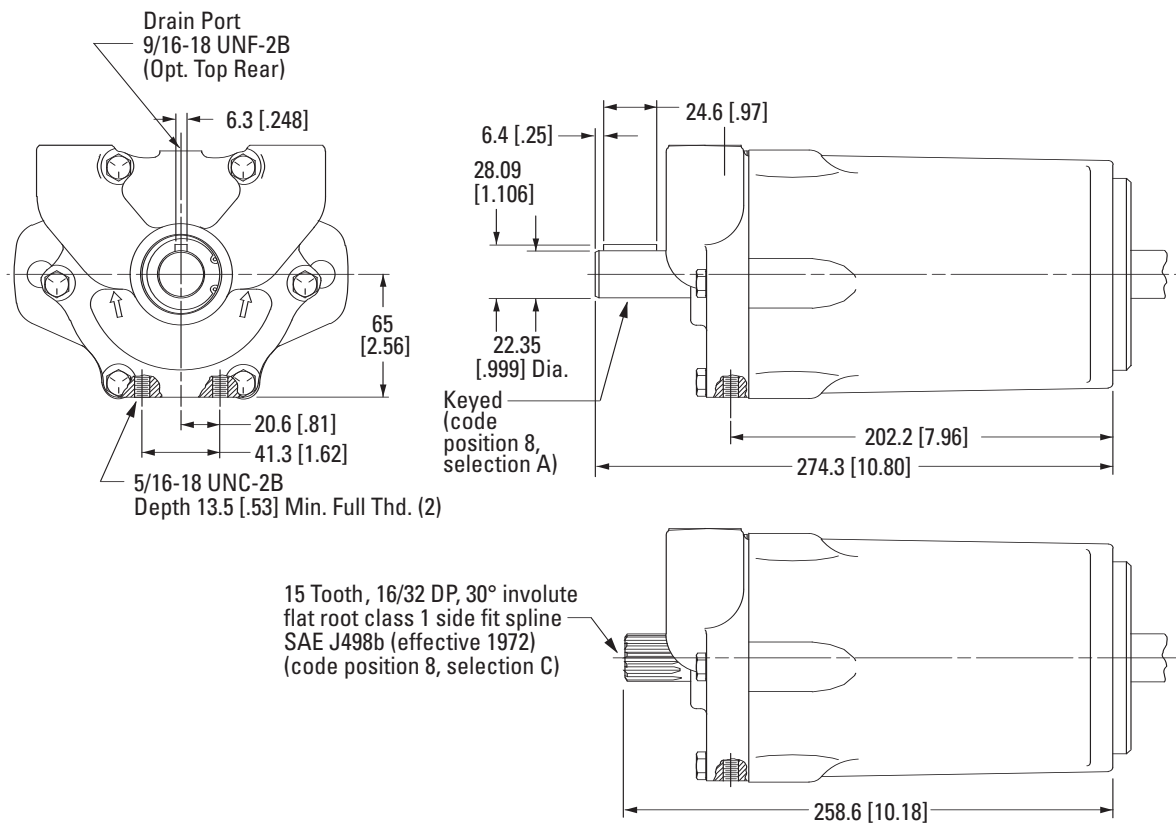

**Note: All ports are SAE (J1926) o-ring ports. Dimensions are in millimeters [inches], unless otherwise specified.**